

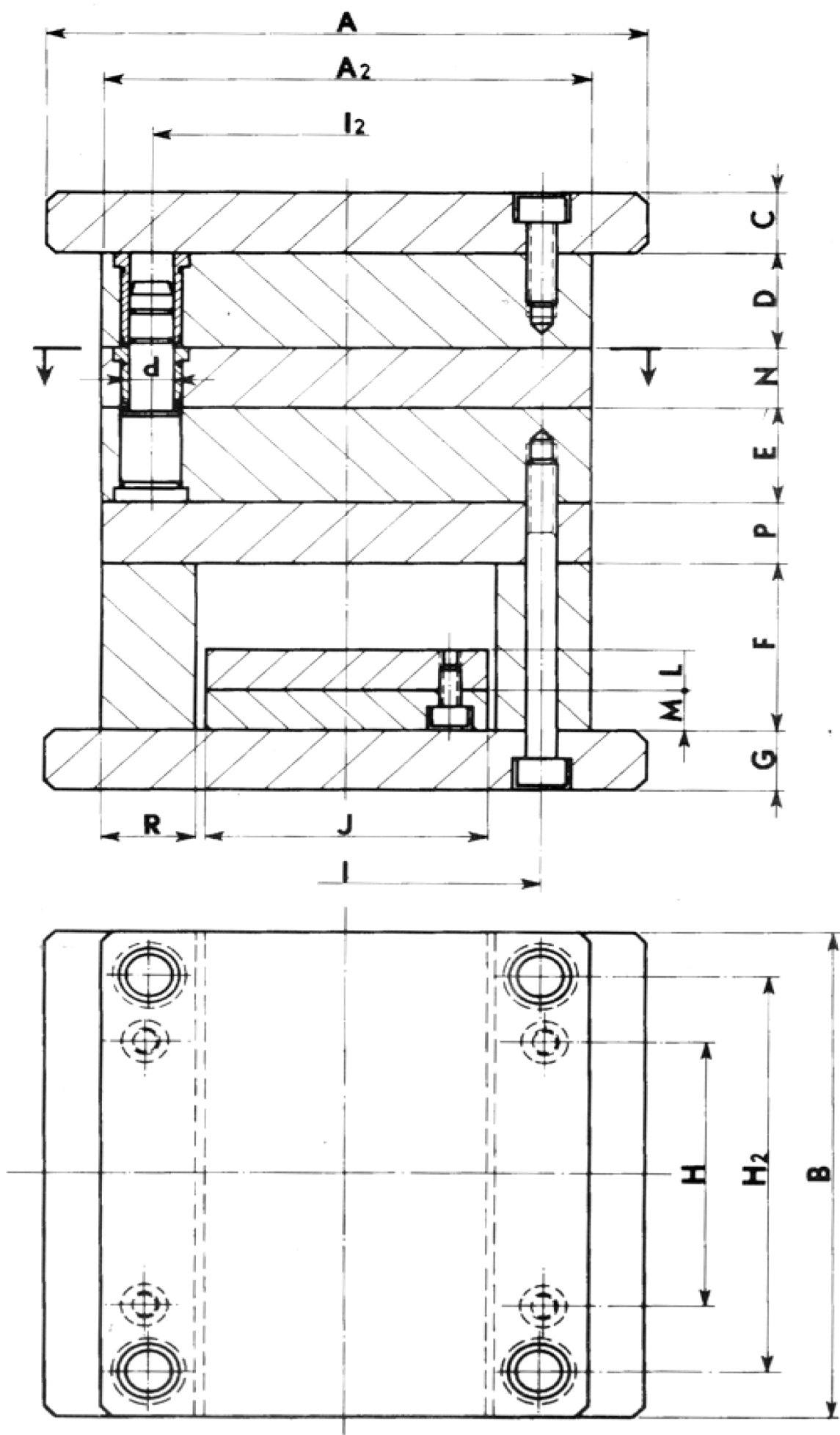

DIE SET LAYOUT

DIE

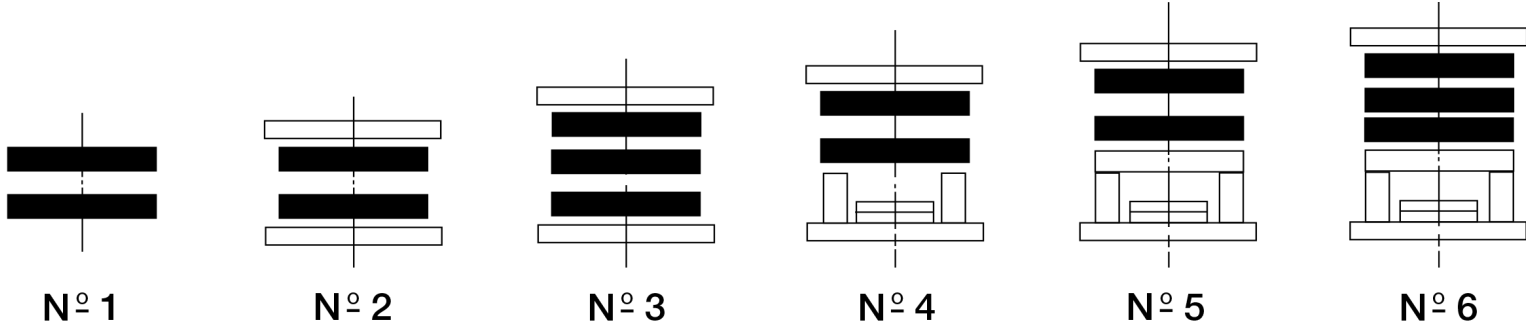



MATERIAL : D N E - CAVITY PLATES 2312 off the shelf. 2311 , 2344, and 2316 Available (2weeks lead time)

: C G P F L M - Mild Steel C-G = Back Plates P = SUPPORT PLATE F = RISERS L+M = EJECTOR PLATES

| TYPE | A | A2 | B | H | H2 | I | I2 | J | D-N-E | F | R | C-G | P | L | M | d |
|-----------|-----|-----|-----|-----|-----|-----|-----|-----|-------------------|----------------|----|----------|----------|----|----|----|
| 130 x 145 | 160 | 130 | 145 | 79 | 119 | 104 | 104 | 75 | 22-27-36 46-56 | 50-60-70 | 26 | 18 | 18 27 | 12 | 14 | 12 |
| 145 x 195 | 175 | 145 | 195 | 117 | 165 | 119 | 115 | 90 | 22-27-36 46-56 | 50-60-70 | 26 | 22 | 27 | 12 | 16 | 16 |
| 175 x 175 | 210 | 175 | 175 | 90 | 140 | 149 | 140 | 120 | 22-27-36 46-56 | 50-60-70-90 | 26 | 22 | 22 27 | 12 | 18 | 16 |
| 175 x 260 | 210 | 175 | 260 | 176 | 225 | 149 | 140 | 120 | 22-27-36 46-56 | 50-60-70 | 26 | 22 | 27 | 12 | 18 | 16 |
| 196 x 196 | 246 | 196 | 196 | 100 | 152 | 154 | 154 | 118 | 22-27-36 46-56 | 56-66-76 | 38 | 22 | 27 | 12 | 18 | 18 |
| 215 x 215 | 250 | 215 | 215 | 130 | 180 | 183 | 180 | 148 | 22-27-36 46-56 | 50-60-70 | 32 | 22 | 22 27 | 12 | 18 | 16 |
| 215 x 295 | 250 | 215 | 295 | 202 | 255 | 183 | 175 | 148 | 22-27-36 46-56 | 60-70 | 32 | 22 | 27 | 12 | 18 | 18 |
| 246 x 246 | 296 | 246 | 246 | 148 | 203 | 209 | 203 | 170 | 22-27-36 46-56 | 66-76-86 | 36 | 27 | 27 | 12 | 18 | 18 |
| 246 x 296 | 296 | 246 | 296 | 186 | 244 | 200 | 200 | 158 | 22-27-36 46-56 | 76 | 43 | 27 | 27 | 12 | 18 | 22 |
| 296 x 296 | 346 | 296 | 296 | 186 | 244 | 250 | 250 | 208 | 27-36-46 56 | 76-86-96 | 43 | 27 | 27 | 12 | 18 | 22 |
| 245 x 360 | 280 | 245 | 360 | 260 | 318 | 209 | 203 | 170 | 22-27-36 46-56 | 70-80-90 | 36 | 27 | 27 | 12 | 18 | 18 |
| 346 x 346 | 396 | 346 | 346 | 224 | 294 | 294 | 294 | 258 | 22-27-36 46-56 | 56-66-76 96 | 43 | 27 36 | 27 36 | 18 | 22 | 22 |
| 396 x 396 | 446 | 396 | 396 | 230 | 324 | 324 | 324 | 268 | 22-27-36 46-56 | 56-66-76 96 | 62 | 27 36 | 27 36 | 18 | 22 | 30 |

MAX - 500 X 700 FULL SPEC SHEETS ARE AVAILABLE ON EACH SIZE

130x145 up to 296x296 is available off the shelf. Special size die set can be made up, 2 week delivery time.

ORDER : VAP DIE SET - NO. 6 - SIZE - D N E P F

ORDER : VAP DIE SET - NO.4 - SIZE - D E F

EXAMPLE : VAP DIE SET - NO. 6 - 246x246 - 36 22 46 27 76

EXAMPLE : VAP DIE SET - NO.4 - 145x195 - 27 36 50

COMES WITH EXTRA STRIPPER PLATE

HAS NO SUPPORT PLATE



130 x 145

DIE

CLAMP PLATE

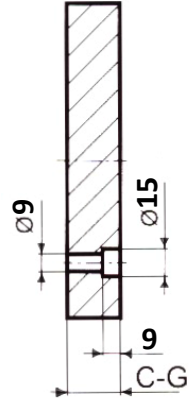
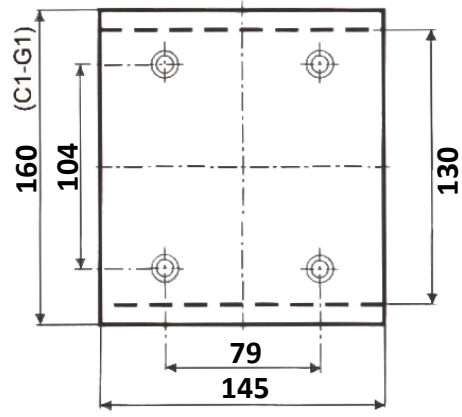
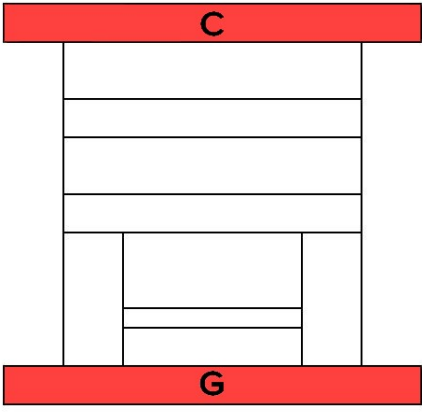

| |
|--------------|
| C - G |
| 18 |

Material - Mild Steel

DIE PLATE

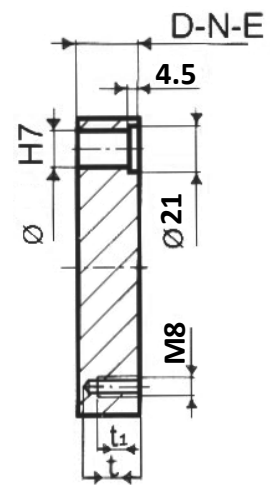
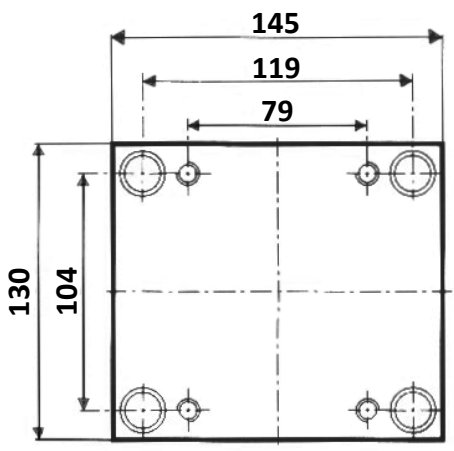
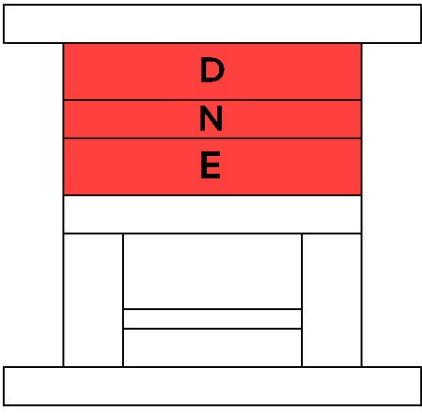

| | | |
|--------------|----|----|
| D-N-E | | |
| 22 | 27 | 36 |
| 46 | 56 | |

Material - 2312

| | | |
|-------|--------|----|
| t_1 | DNE=22 | 15 |
| | DNE>22 | 18 |
| t | DNE=22 | 20 |
| | DNE>22 | 25 |

SUPPORT

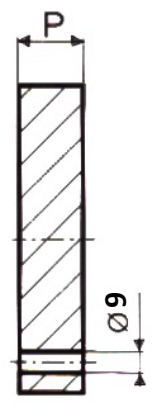
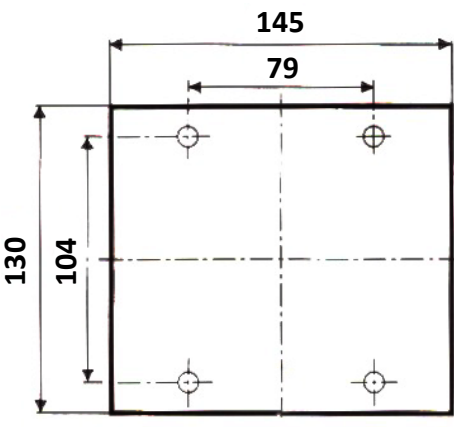
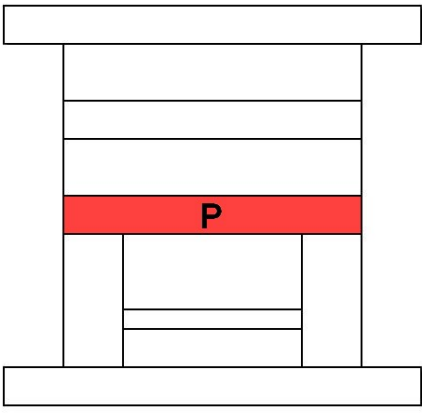

| | |
|----------|----|
| P | |
| 18 | 27 |

Material - Mild Steel

RISERS

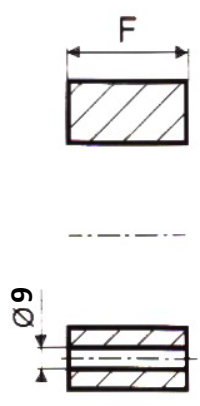
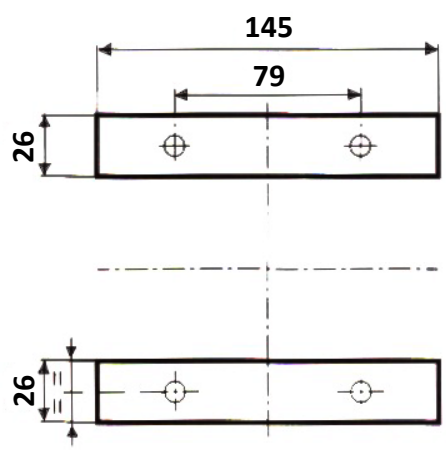
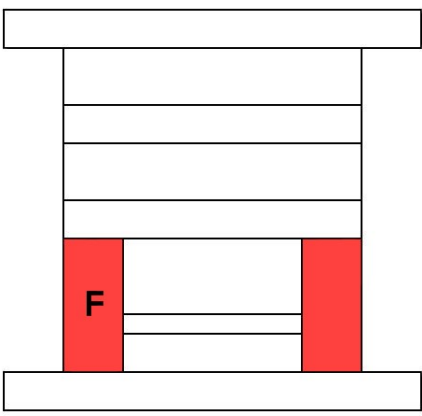

| | | |
|----------|----|----|
| F | | |
| 50 | 60 | 70 |

Material - Mild Steel



145 x 195

DIE

CLAMP PLATE

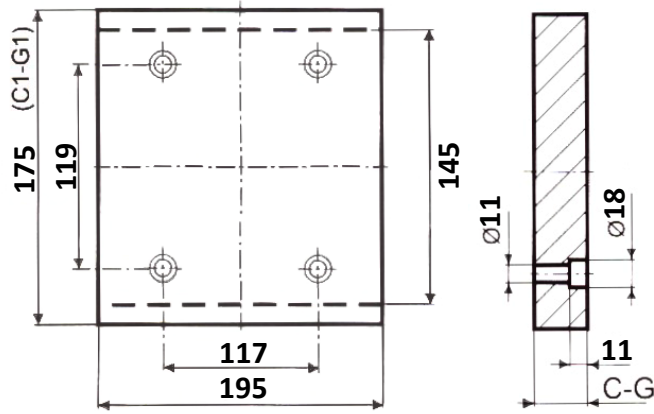
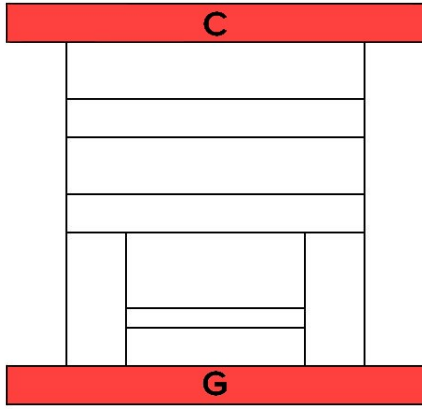

| |
|-------|
| C - G |
| 22 |

Material - Mild Steel

DIE PLATE

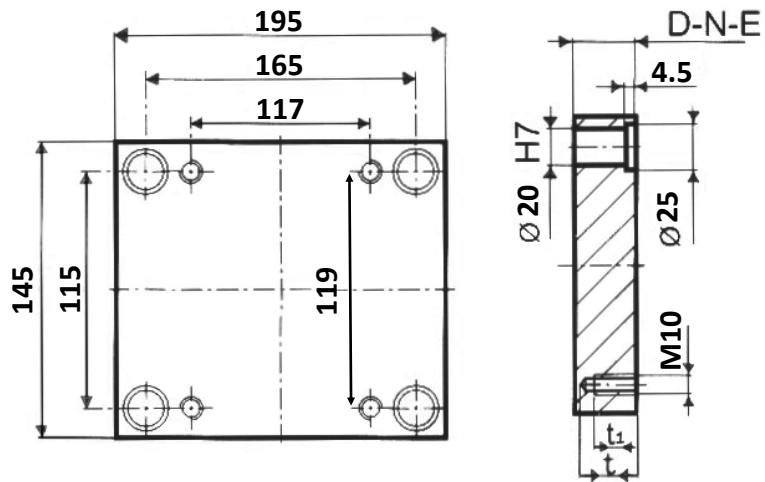
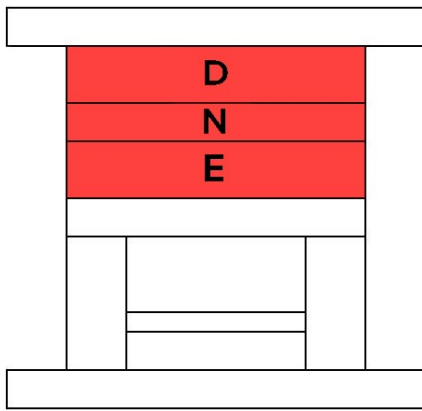

| | | |
|-------|----|----|
| D-N-E | | |
| 22 | 27 | 36 |
| 46 | 56 | |

Material - 2312

| | | |
|----------------|--------|----|
| t ₁ | DNE=22 | 15 |
| | DNE>22 | 18 |
| t | DNE=22 | 20 |
| | DNE>22 | 25 |

SUPPORT

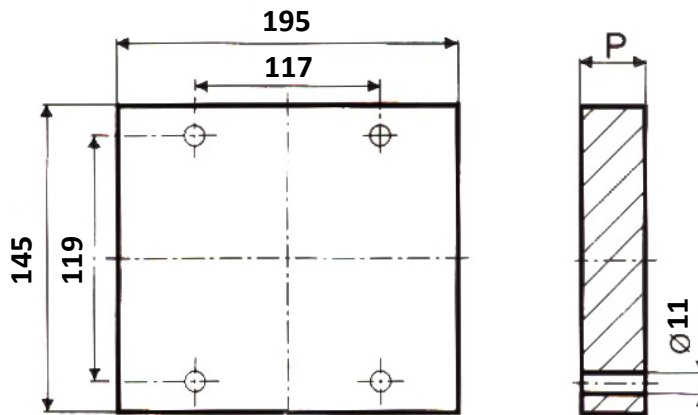
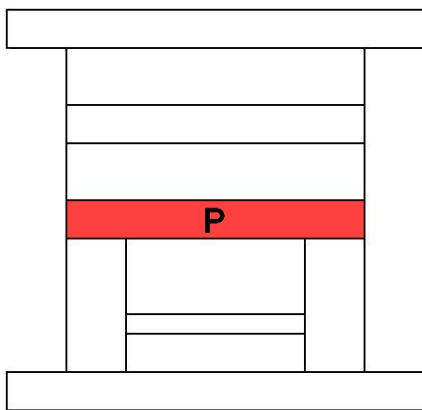

| | |
|----|----|
| P | |
| 22 | 27 |

Material - Mild Steel

RISERS

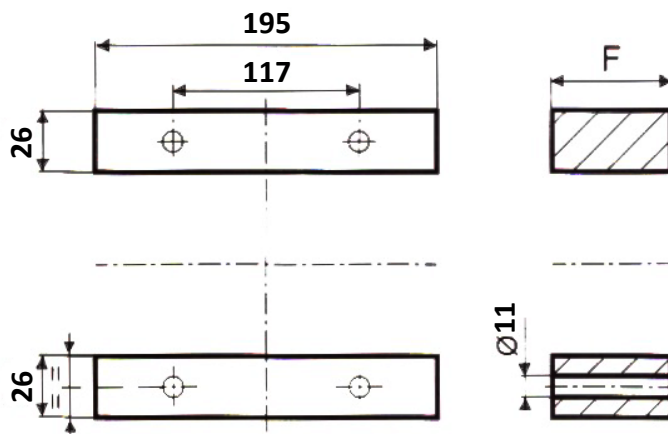
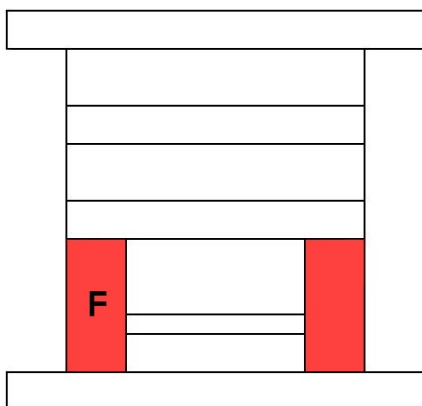

| | | |
|----|----|----|
| F | | |
| 50 | 60 | 70 |

Material - Mild Steel

CLAMP PLATE

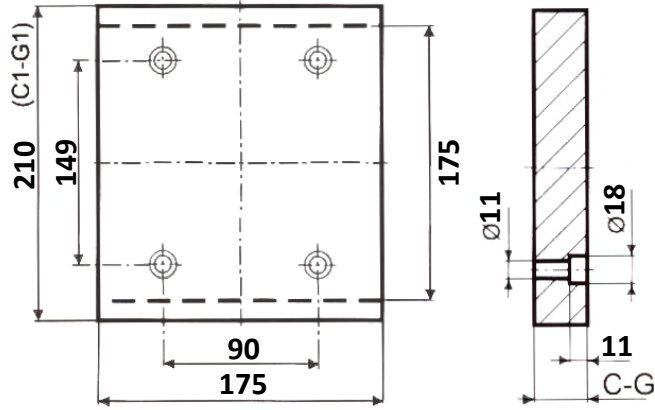
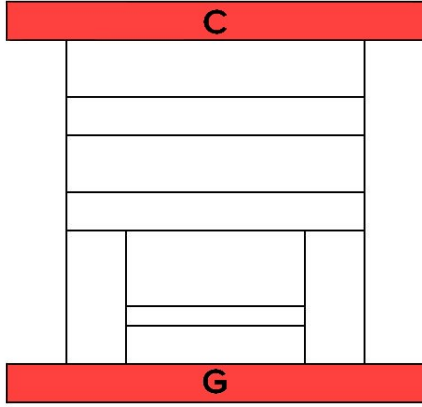

| |
|--------------|
| C - G |
| 22 |

Material - Mild Steel

DIE PLATE

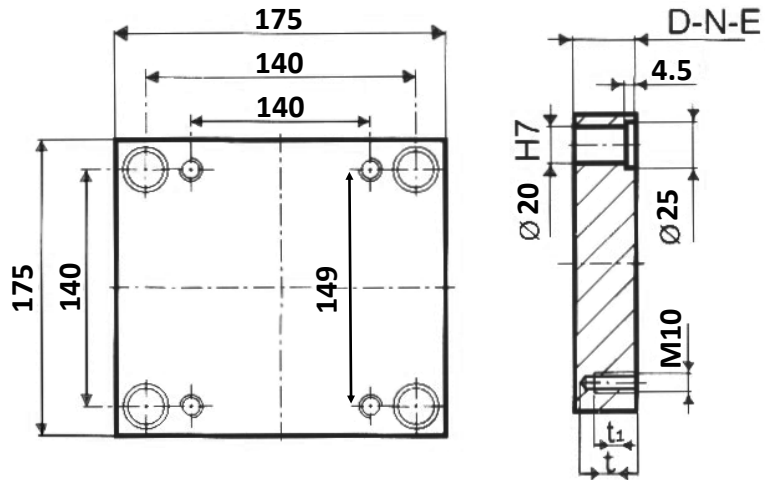
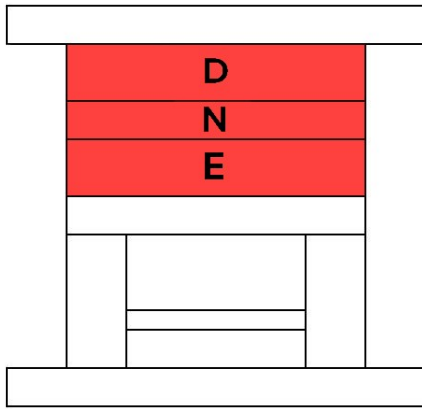

| | | |
|--------------|----|----|
| D-N-E | | |
| 22 | 27 | 36 |
| 46 | 56 | 76 |

Material - 2312

| | | |
|----------------|--------|----|
| t ₁ | DNE=22 | 15 |
| | DNE>22 | 18 |
| t | DNE=22 | 20 |
| | DNE>22 | 25 |

SUPPORT

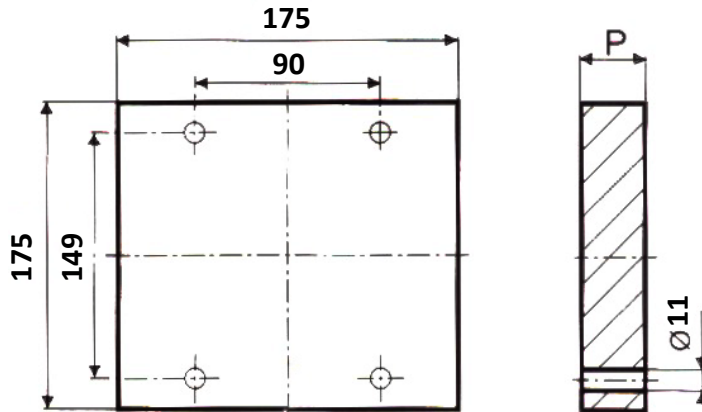
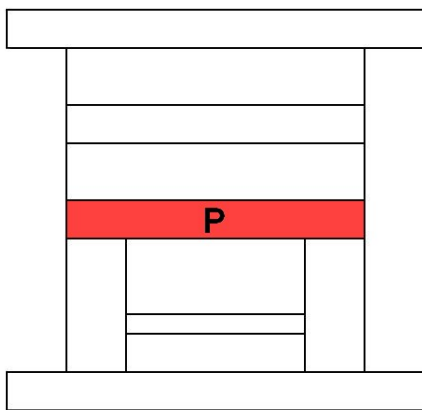

| | |
|----------|----|
| P | |
| 22 | 27 |

Material - Mild Steel

RISERS

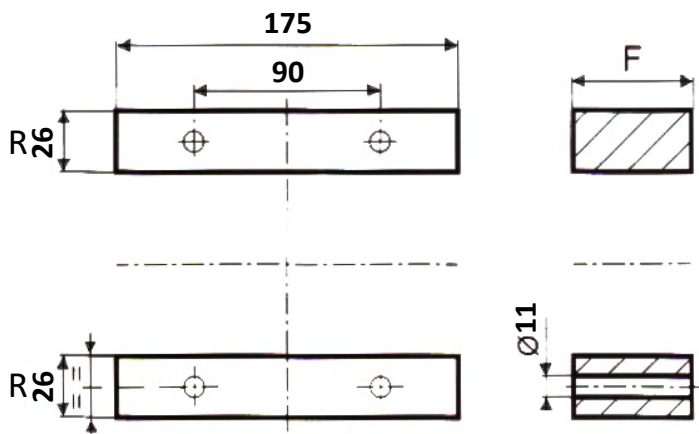
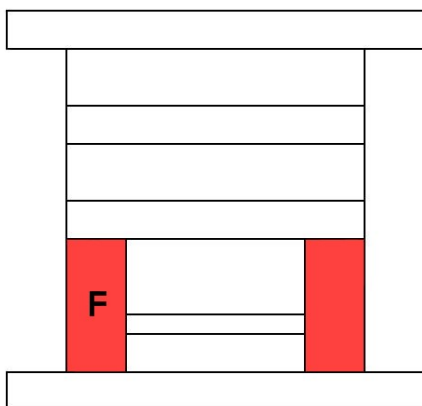

| | | |
|----------|----|----|
| F | | |
| 50 | 60 | 70 |

Material - Mild Steel

CLAMP PLATE

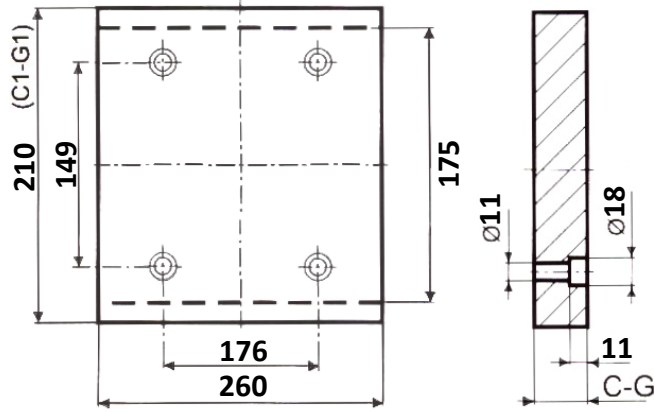
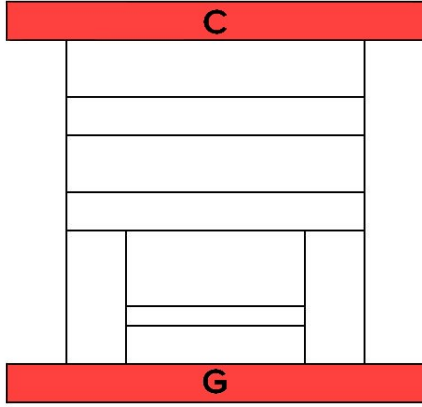

| |
|--------------|
| C - G |
| 22 |

Material - Mild Steel

DIE PLATE

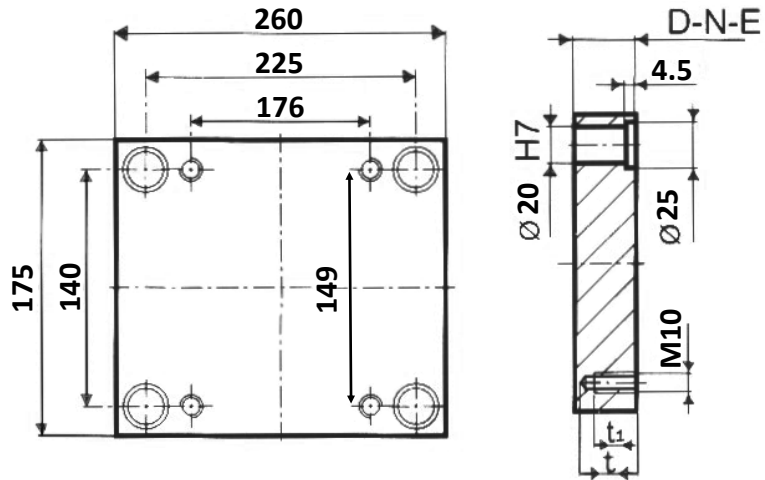
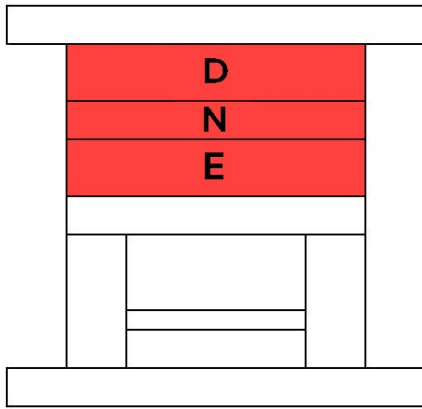

| | | |
|--------------|----|----|
| D-N-E | | |
| 22 | 27 | 36 |
| 46 | 56 | 76 |

Material - 2312

| | | |
|----------------|--------|----|
| t ₁ | DNE=22 | 15 |
| | DNE>22 | 18 |
| t | DNE=22 | 20 |
| | DNE>22 | 25 |

SUPPORT

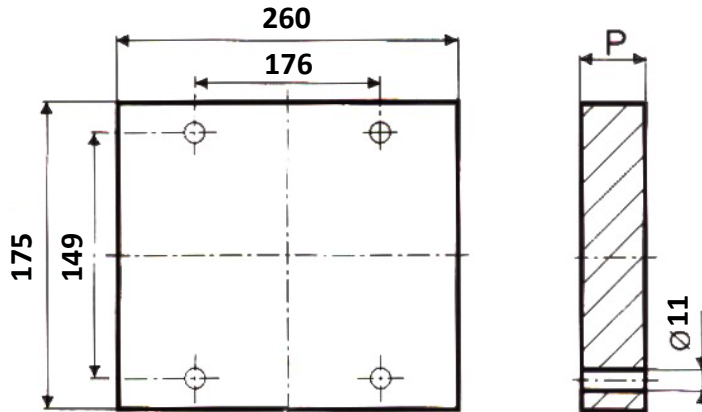
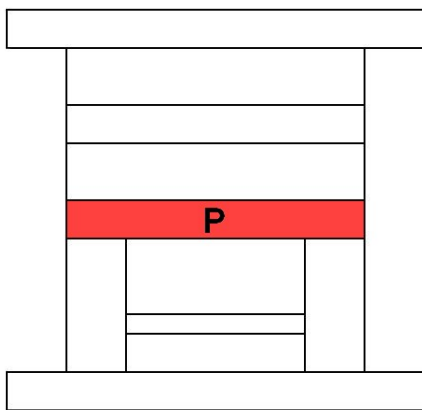

| | |
|----------|----|
| P | |
| 22 | 27 |

Material - Mild Steel

RISERS

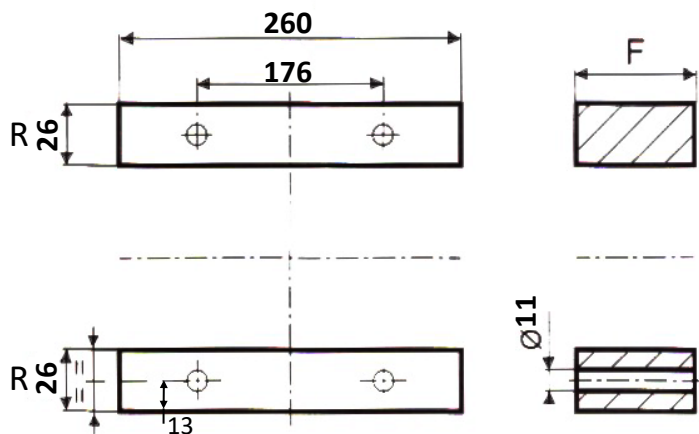
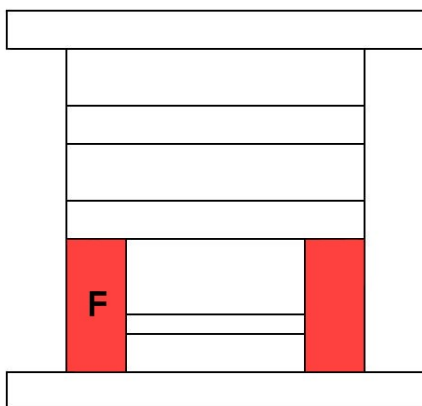

| | | |
|----------|----|----|
| F | | |
| 50 | 60 | 70 |

Material - Mild Steel

| | |
|----------|----|
| R | |
| 26 | 36 |



175 x 360

DIE

CLAMP PLATE

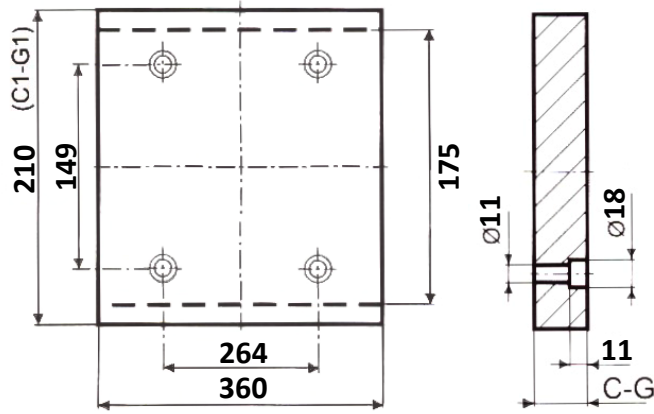
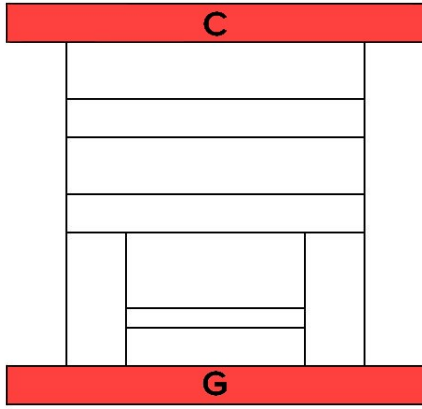

| |
|-------|
| C - G |
| 22 |

Material - Mild Steel

DIE PLATE

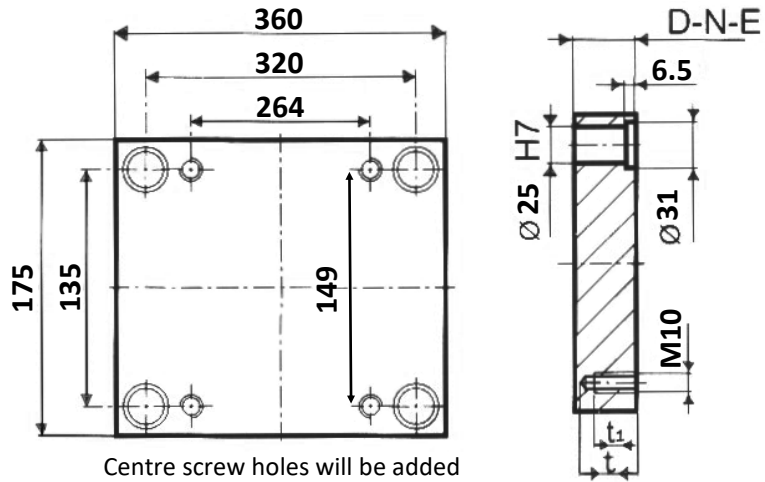
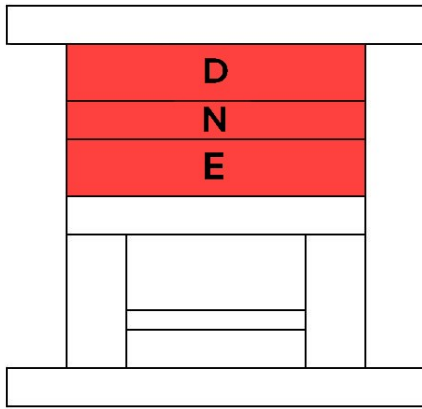

| | | |
|-------|----|----|
| D-N-E | | |
| 22 | 27 | 36 |
| 46 | 56 | 76 |

Material - 2312

| | | |
|----------------|--------|----|
| t ₁ | DNE=22 | 15 |
| | DNE>22 | 18 |
| t | DNE=22 | 20 |
| | DNE>22 | 25 |

SUPPORT

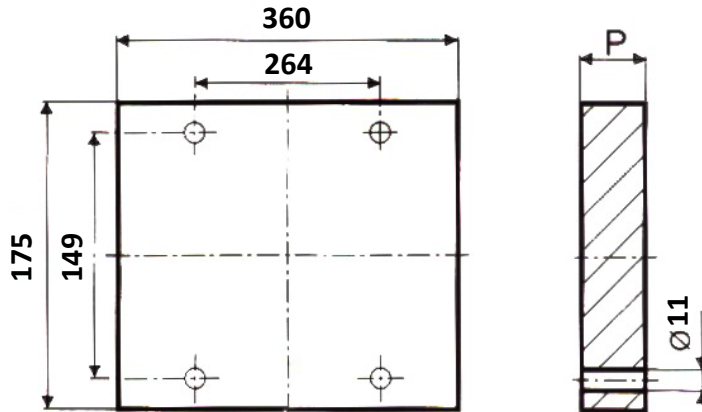
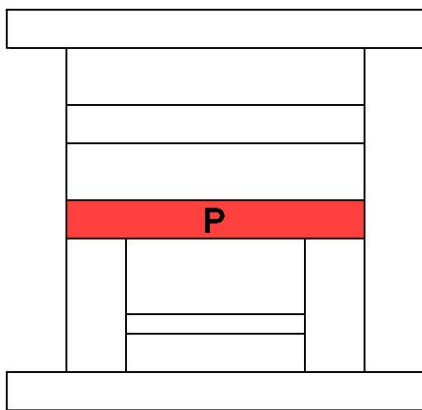

| | |
|----|----|
| P | |
| 22 | 27 |

Material - Mild Steel

RISERS

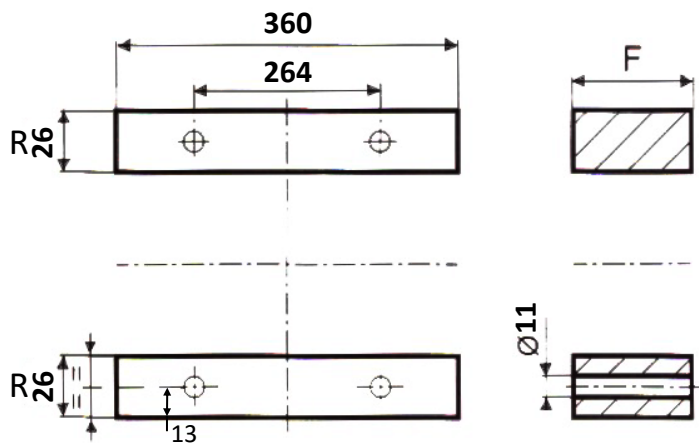
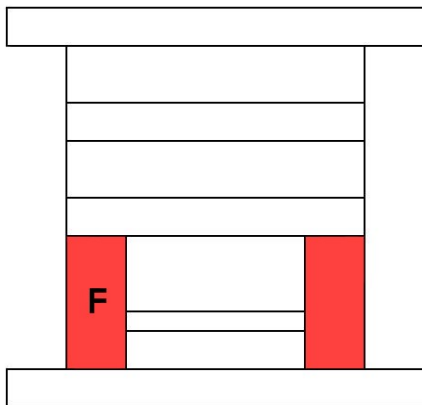

| | | |
|----|----|----|
| F | | |
| 50 | 60 | 70 |

Material - Mild Steel

| | |
|----|----|
| R | |
| 26 | 36 |

CLAMP PLATE

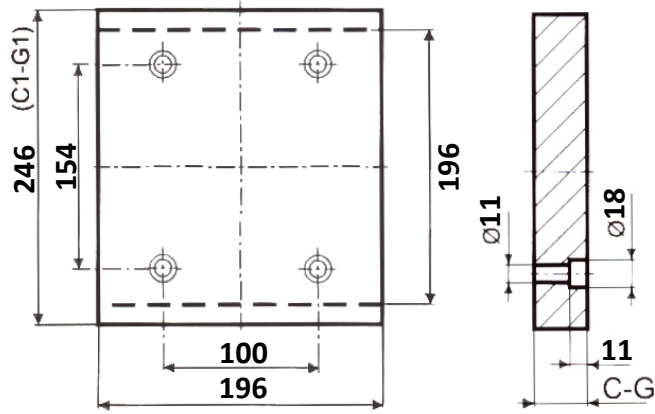
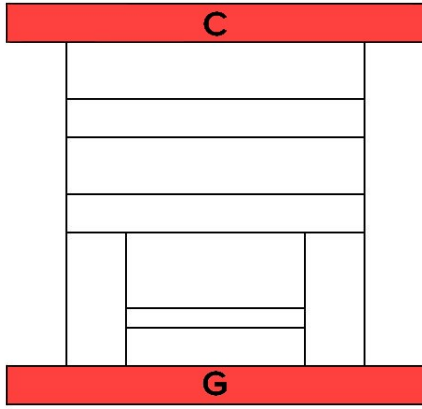

| |
|--------------|
| C - G |
| 22 |

Material - Mild Steel

DIE PLATE

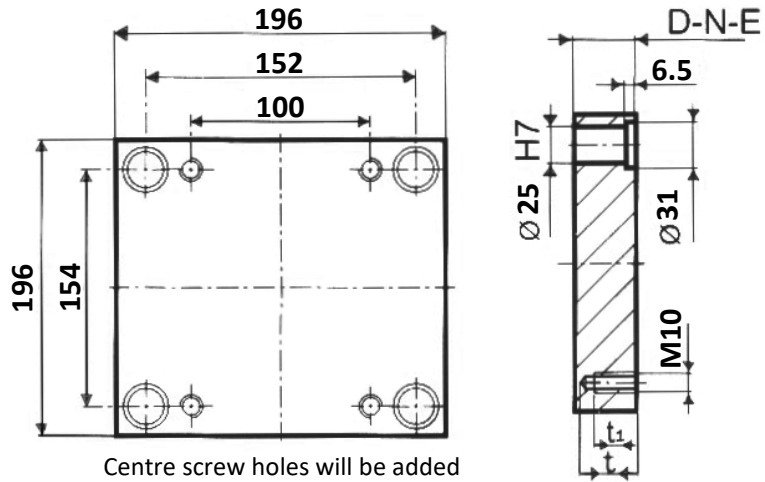
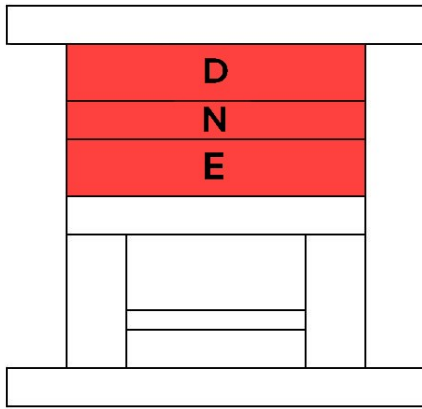

| | | |
|--------------|----|----|
| D-N-E | | |
| 22 | 27 | 36 |
| 46 | 56 | 76 |

Material - 2312

| | | |
|----------------|--------|----|
| t ₁ | DNE=22 | 15 |
| | DNE>22 | 18 |
| t | DNE=22 | 20 |
| | DNE>22 | 25 |

SUPPORT

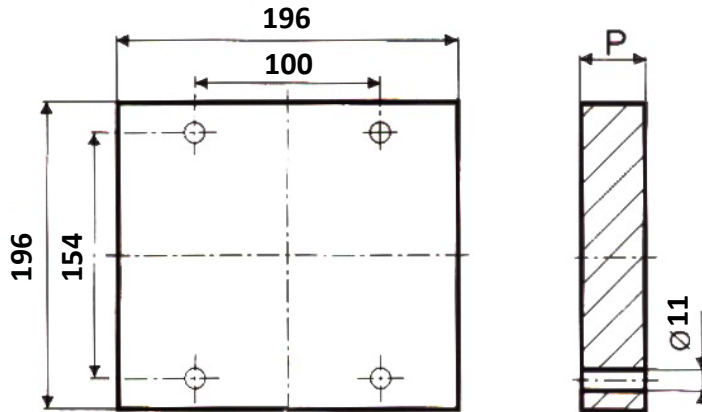
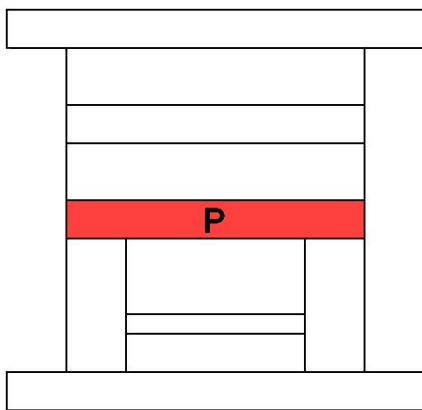

| | |
|----------|----|
| P | |
| 22 | 27 |

Material - Mild Steel

RISERS

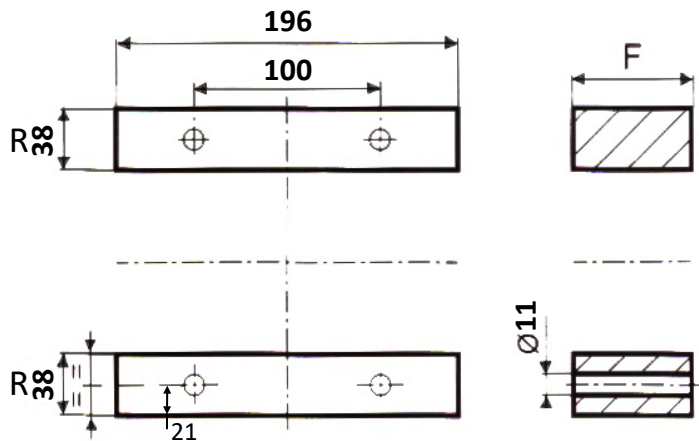
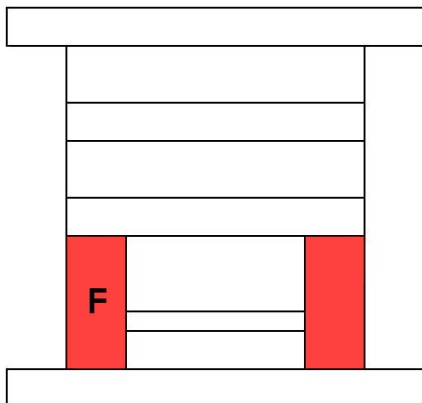

| | | |
|----------|----|----|
| F | | |
| 50 | 60 | 70 |

Material - Mild Steel

| |
|----------|
| R |
| 38 |



196 x 296

DIE

CLAMP PLATE

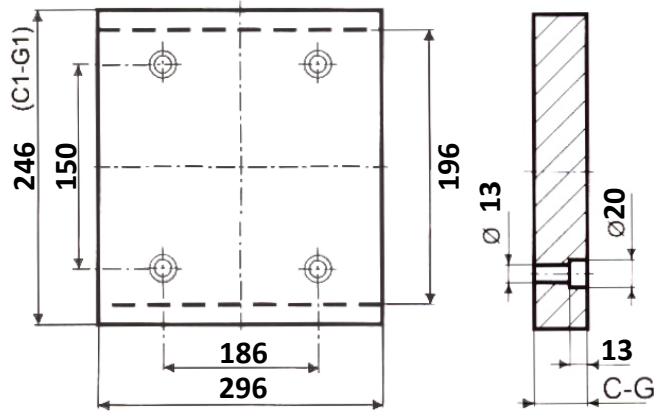
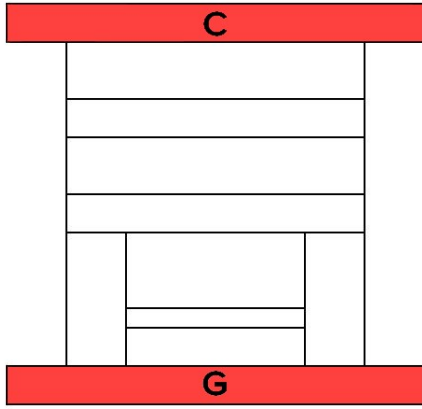

| |
|--------------|
| C - G |
| 22 or 27 |

Material - Mild Steel

DIE PLATE

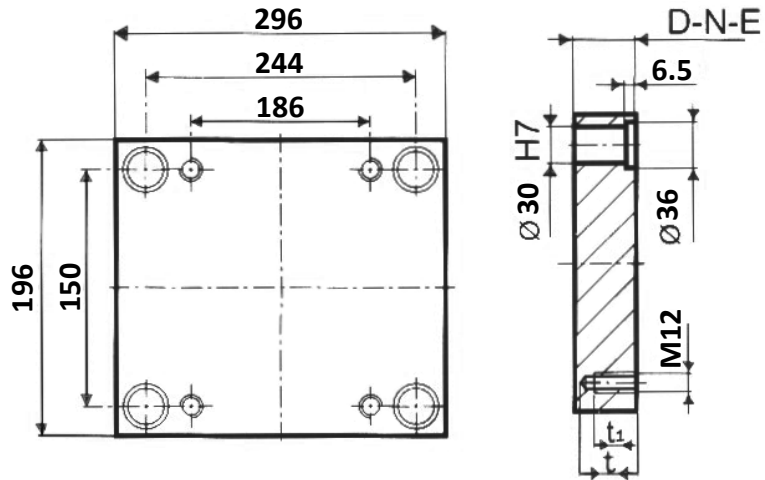
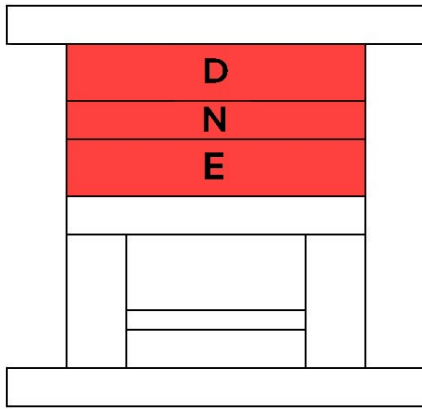

| | | |
|--------------|----|----|
| D-N-E | | |
| 22 | 27 | 36 |
| 46 | 56 | 76 |

Material - 2312

| | | |
|----------------|--------|----|
| t ₁ | DNE=22 | 15 |
| | DNE>22 | 18 |
| t | DNE=22 | 20 |
| | DNE>22 | 25 |

SUPPORT

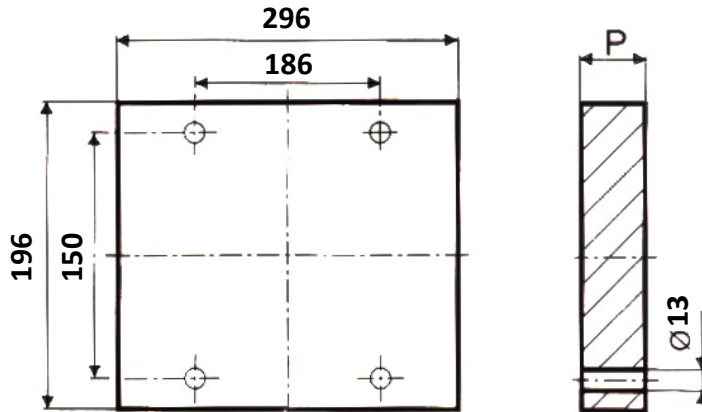
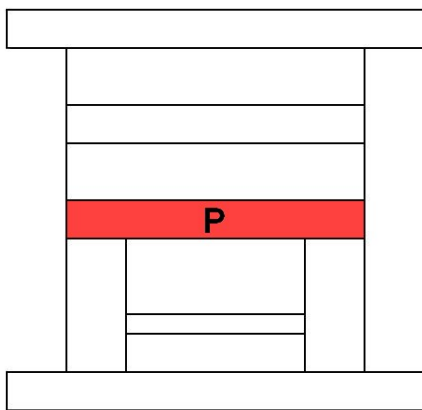

| | |
|----------|----|
| P | |
| 27 | 36 |

Material - Mild Steel

RISERS

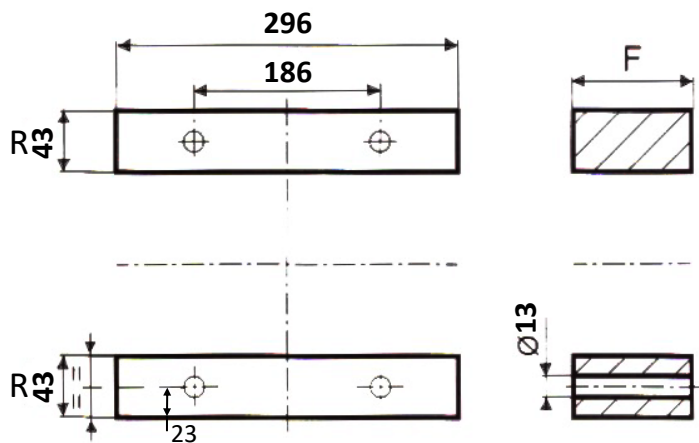
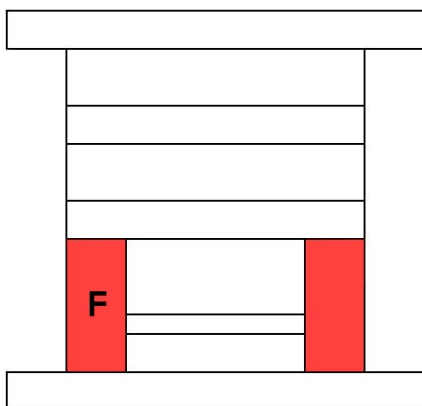

| | | |
|----------|----|----|
| F | | |
| 50 | 60 | 70 |

Material - Mild Steel

| |
|----------|
| R |
| 43 |

CLAMP PLATE

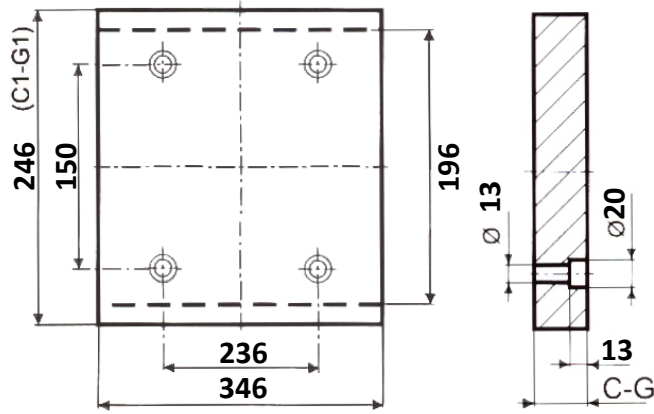
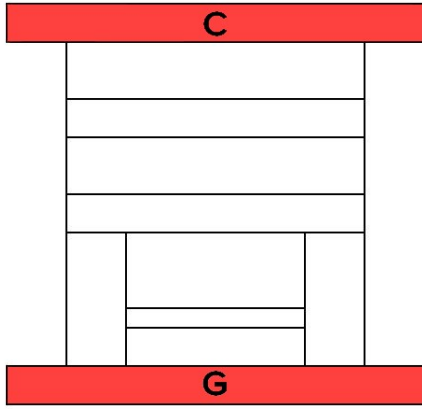

| |
|--------------|
| C - G |
| 27 or 36 |

Material - Mild Steel

DIE PLATE

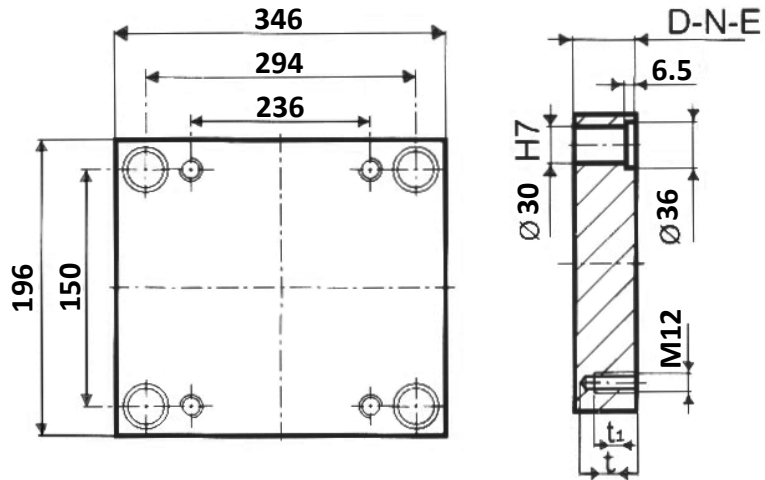
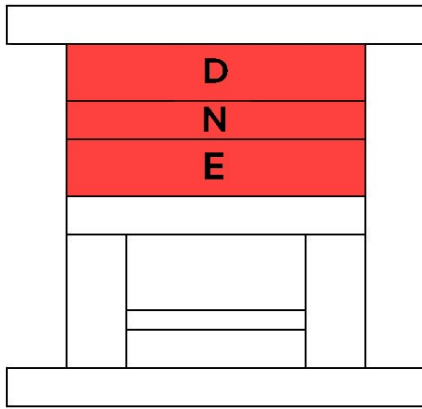

| | | |
|--------------|----|----|
| D-N-E | | |
| 22 | 27 | 36 |
| 46 | 56 | 76 |

Material - 2312

| | | |
|----------------|--------|----|
| t ₁ | DNE=22 | 15 |
| | DNE>22 | 18 |
| t | DNE=22 | 20 |
| | DNE>22 | 25 |

SUPPORT

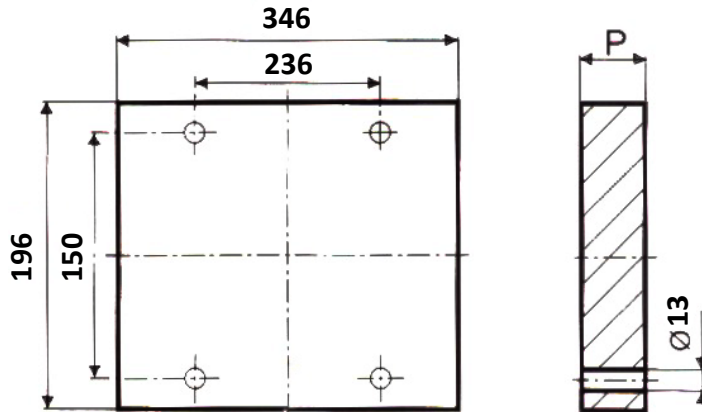
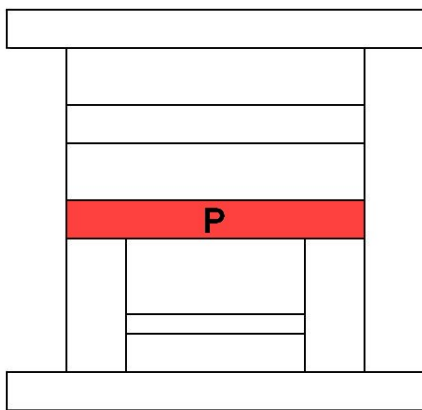

| | |
|----------|----|
| P | |
| 27 | 36 |

Material - Mild Steel

RISERS

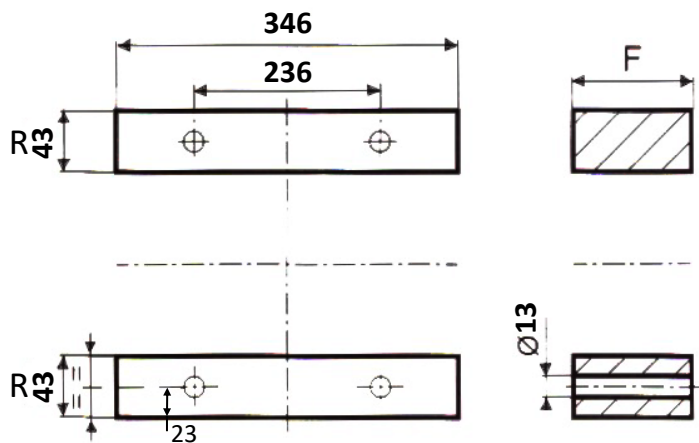
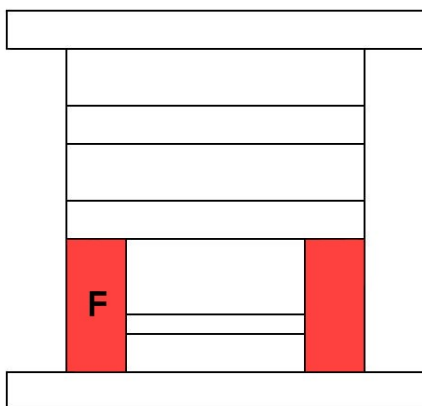

| | | |
|----------|----|----|
| F | | |
| 50 | 60 | 70 |

Material - Mild Steel

| |
|----------|
| R |
| 43 |



196 x 396

DIE

CLAMP PLATE

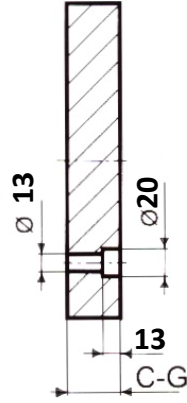
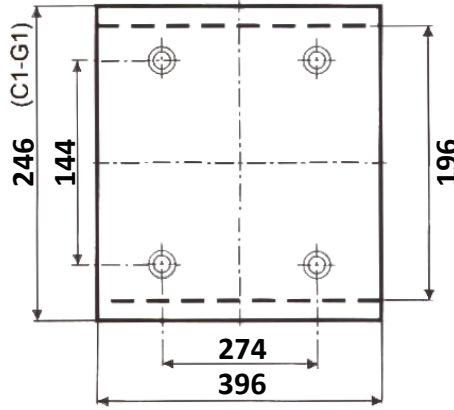
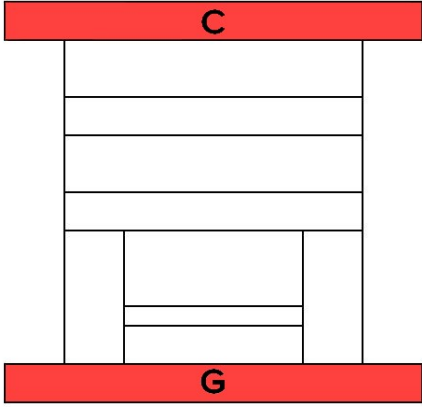

| |
|----------|
| C - G |
| 27 or 36 |

Material - Mild Steel

DIE PLATE

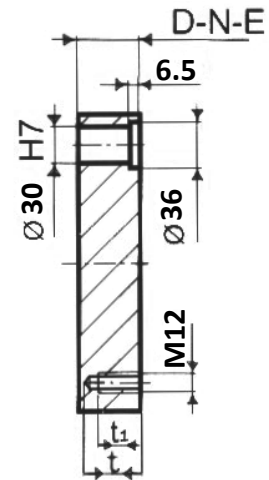
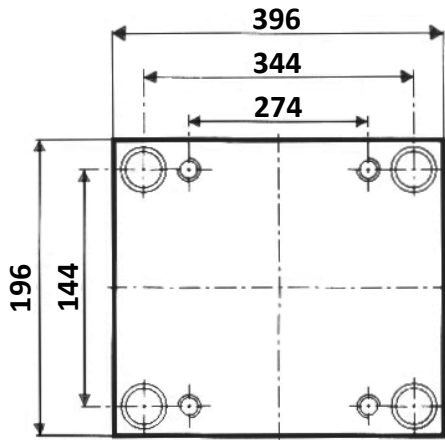
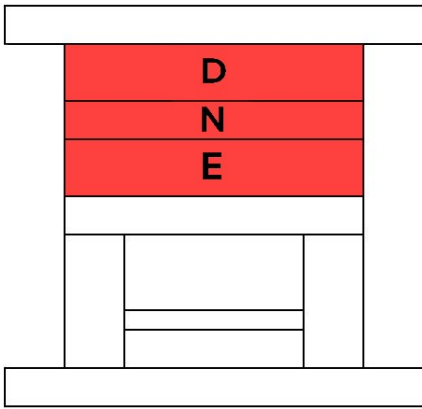

| | | |
|-------|----|----|
| D-N-E | | |
| 22 | 27 | 36 |
| 46 | 56 | 76 |

Material - 2312

| | | |
|----------------|--------|----|
| t ₁ | DNE=22 | 15 |
| | DNE>22 | 18 |
| t | DNE=22 | 20 |
| | DNE>22 | 25 |

SUPPORT

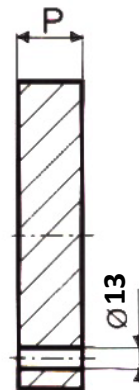
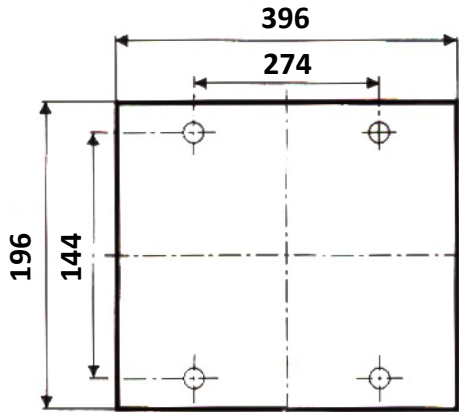
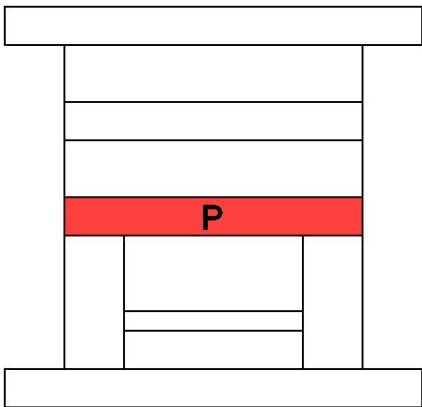

| | |
|----|----|
| P | |
| 27 | 36 |

Material - Mild Steel

RISERS

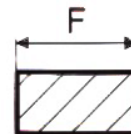
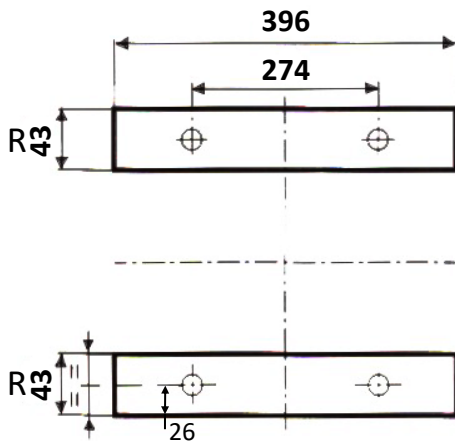
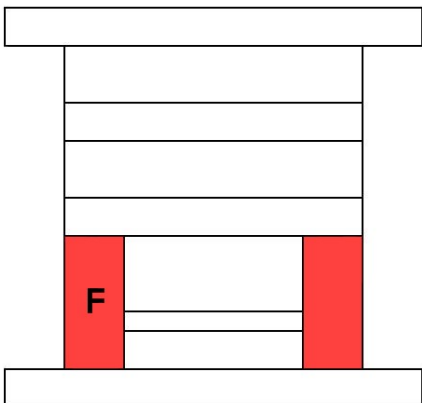

| | | |
|----|----|----|
| F | | |
| 50 | 60 | 70 |

Material - Mild Steel



| |
|----|
| R |
| 43 |



215 x 215

DIE

CLAMP PLATE

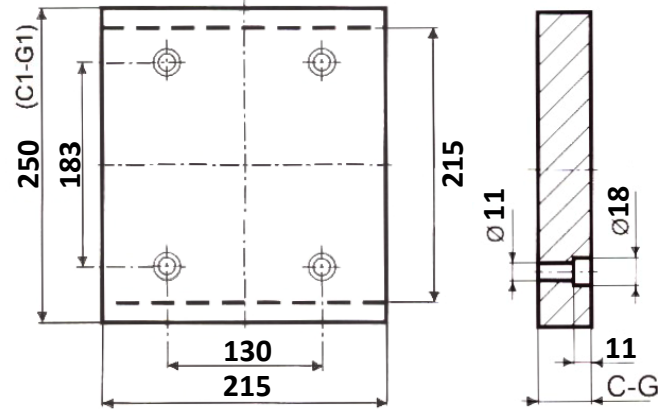
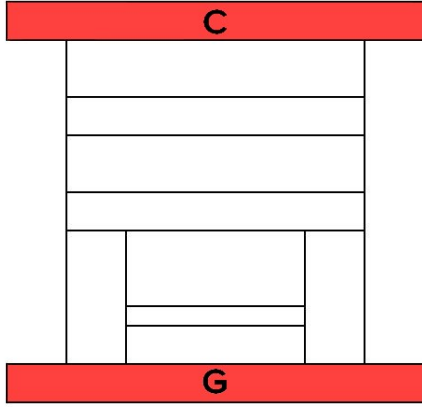

| |
|--------------|
| C - G |
| 22 |

Material - Mild Steel

DIE PLATE

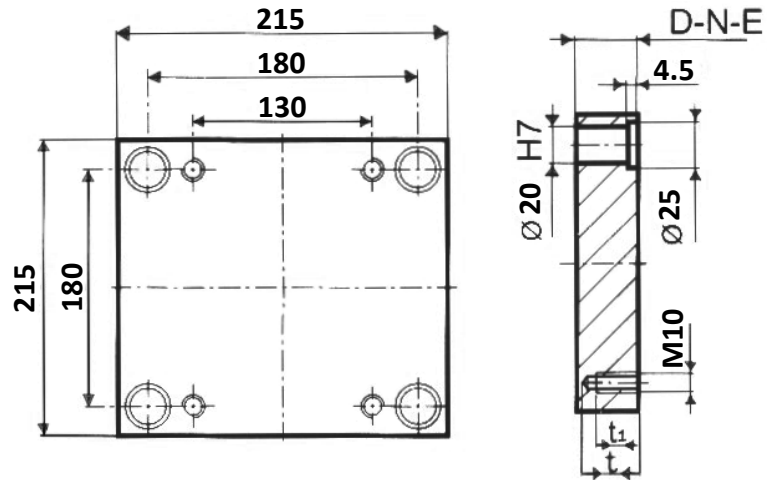
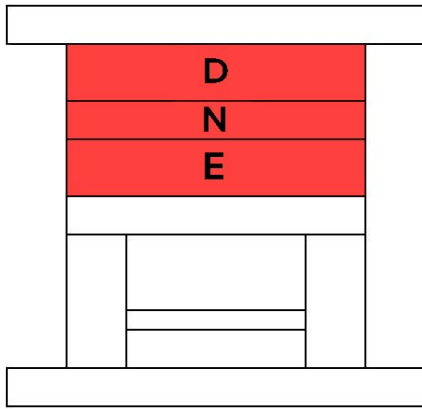

| | | |
|--------------|----|----|
| D-N-E | | |
| 22 | 27 | 36 |
| 46 | 56 | 76 |

Material - 2312

| | | |
|----------------|--------|----|
| t ₁ | DNE=22 | 15 |
| | DNE>22 | 18 |
| t | DNE=22 | 20 |
| | DNE>22 | 25 |

SUPPORT

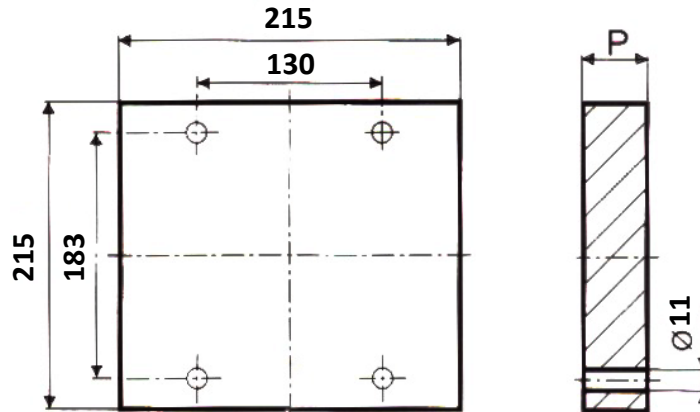
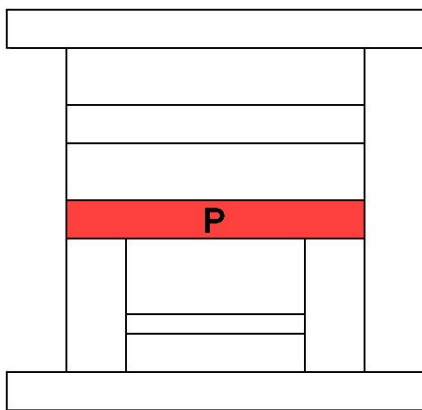

| | |
|----------|----|
| P | |
| 22 | 27 |

Material - Mild Steel

RISERS

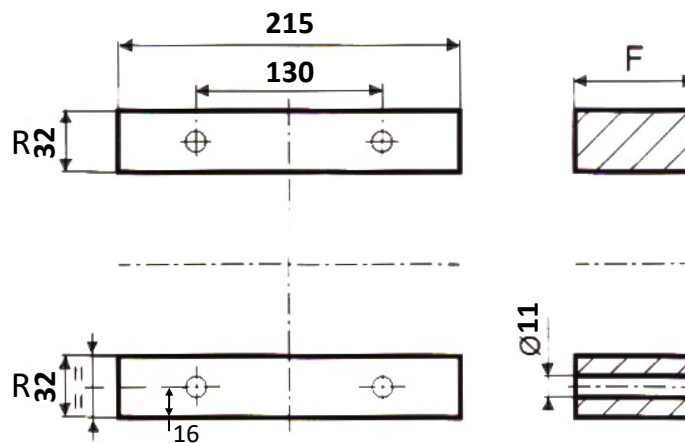
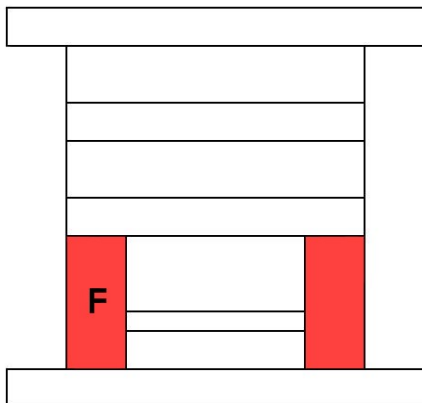

| | | |
|----------|----|----|
| F | | |
| 50 | 60 | 70 |

Material - Mild Steel

| |
|----------|
| R |
| 32 |



215 x 295

DIE

CLAMP PLATE

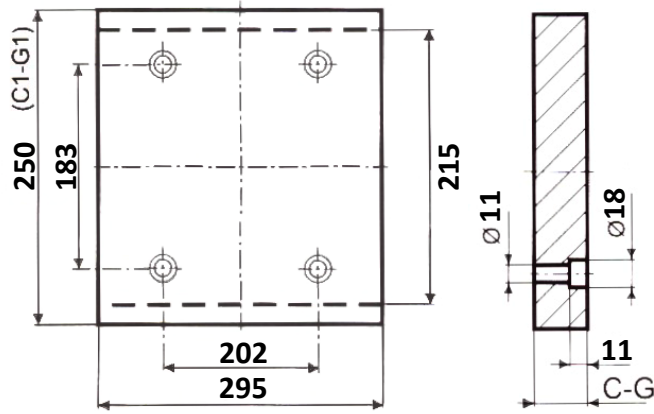
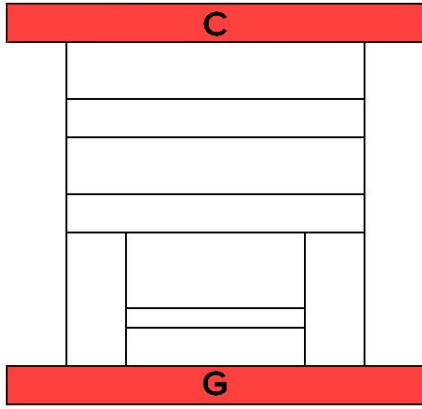

| |
|-------|
| C - G |
| 22 |

Material - Mild Steel

DIE PLATE

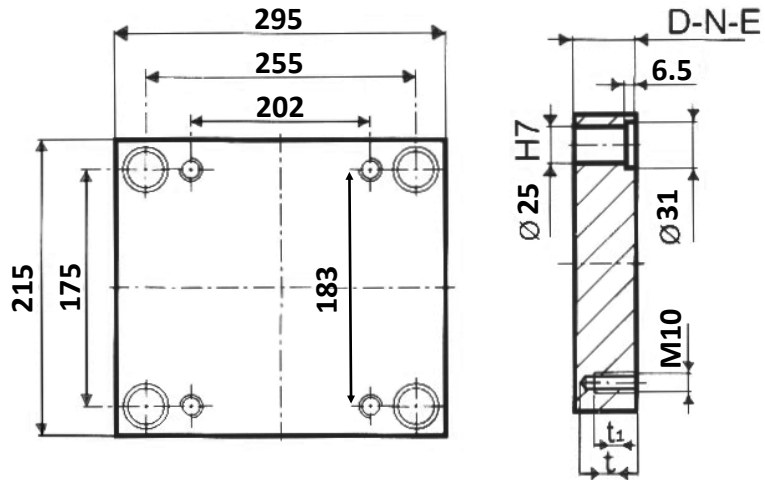
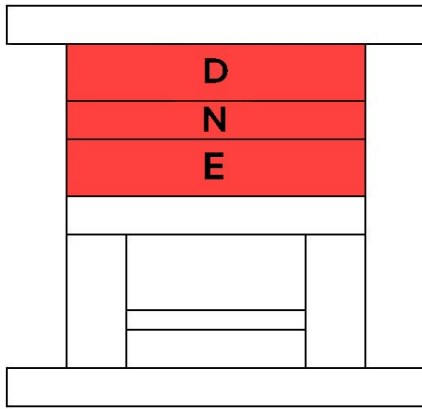

| | | |
|-------|----|----|
| D-N-E | | |
| 22 | 27 | 36 |
| 46 | 56 | 76 |

Material - 2312

| | | |
|----------------|--------|----|
| t ₁ | DNE=22 | 15 |
| | DNE>22 | 18 |
| t | DNE=22 | 20 |
| | DNE>22 | 25 |

SUPPORT

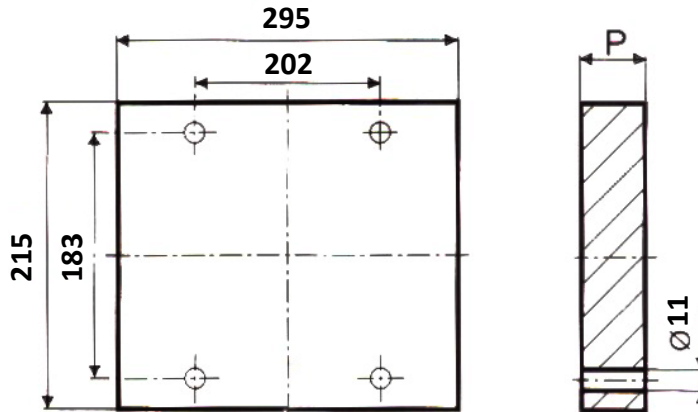
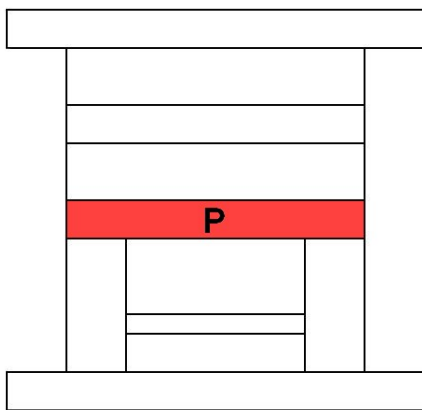

| |
|----|
| P |
| 27 |

Material - Mild Steel

RISERS

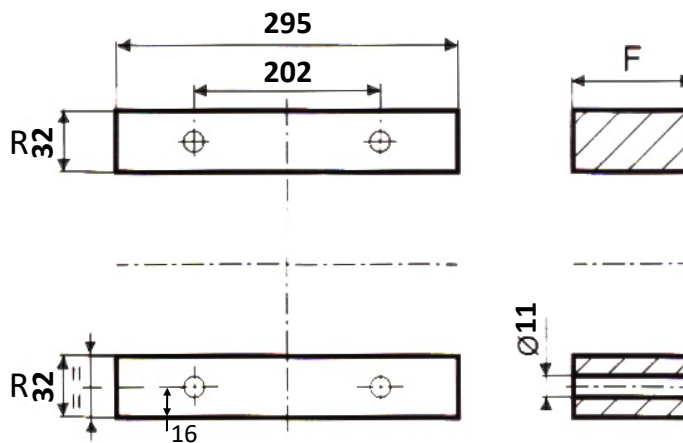
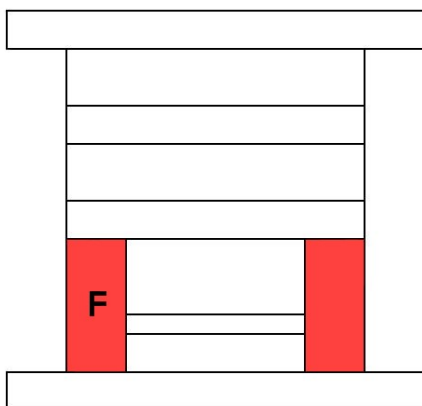

| | | |
|----|----|----|
| F | | |
| 50 | 60 | 70 |

Material - Mild Steel

| |
|----|
| R |
| 32 |



245 x 360

DIE

CLAMP PLATE

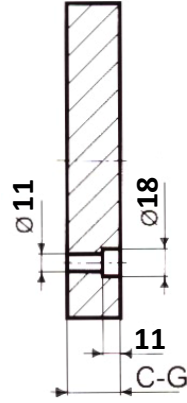
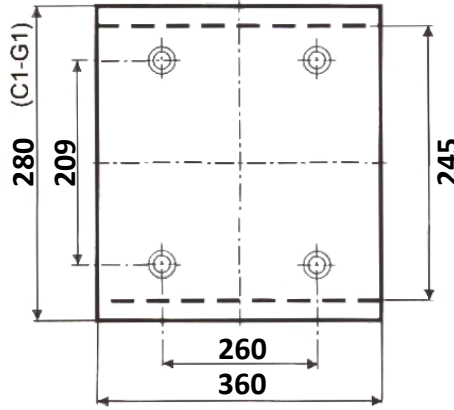
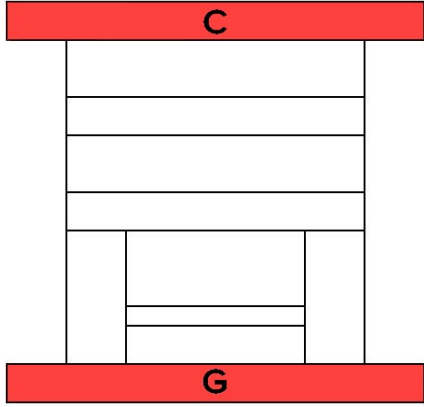

| |
|-------|
| C - G |
| 22 |

Material - Mild Steel

DIE PLATE

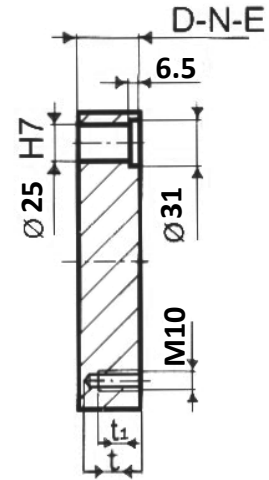
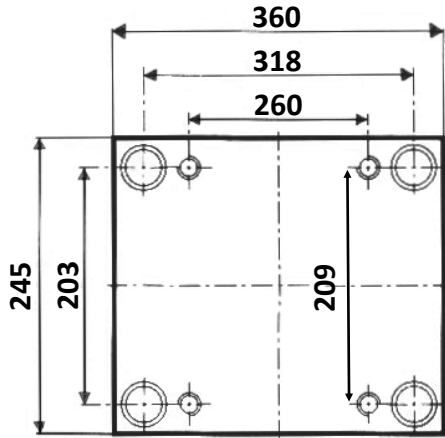
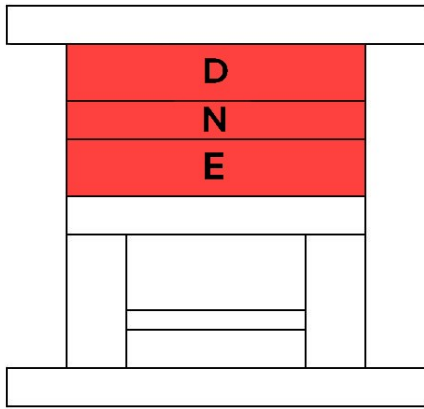

| | | |
|-------|----|----|
| D-N-E | | |
| 22 | 27 | 36 |
| 46 | 56 | 76 |

Material - 2312

| | | |
|----------------|--------|----|
| t ₁ | DNE=22 | 15 |
| | DNE>22 | 18 |
| t | DNE=22 | 20 |
| | DNE>22 | 25 |

SUPPORT

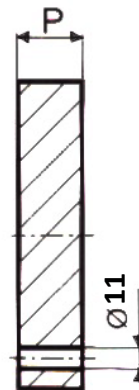
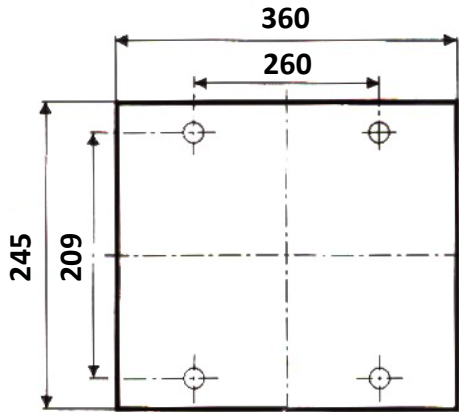
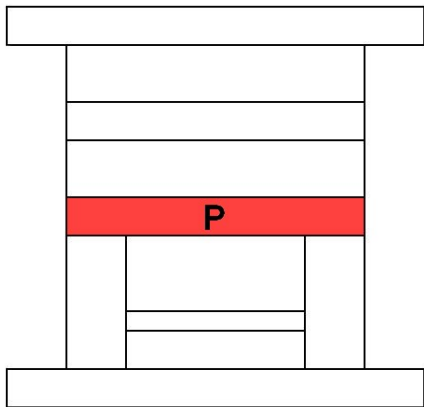

| |
|----|
| P |
| 27 |

Material - Mild Steel

RISERS

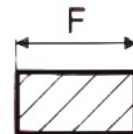
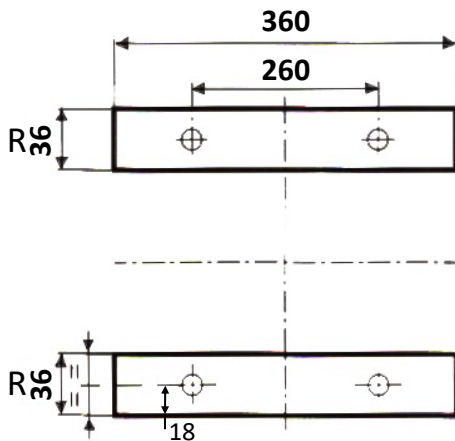
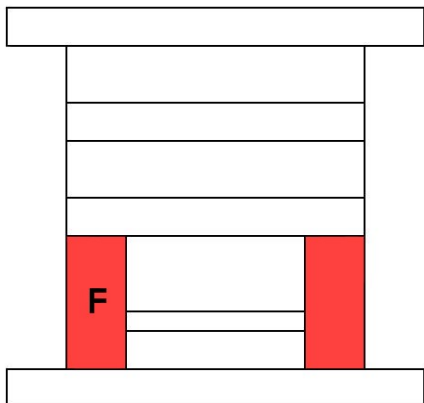

| | | |
|----|----|----|
| F | | |
| 50 | 60 | 70 |

Material - Mild Steel

| |
|----|
| R |
| 36 |



246 x 246

DIE

CLAMP PLATE

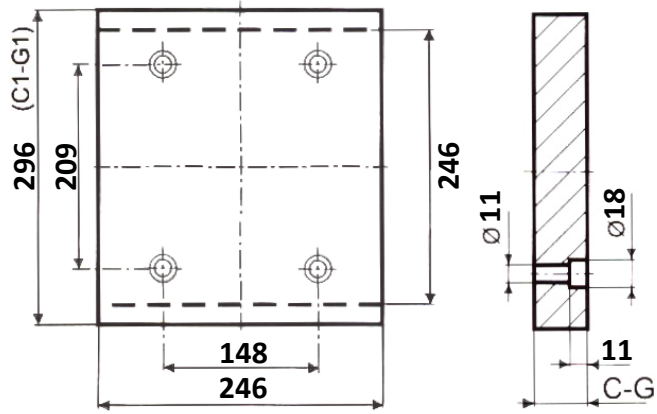
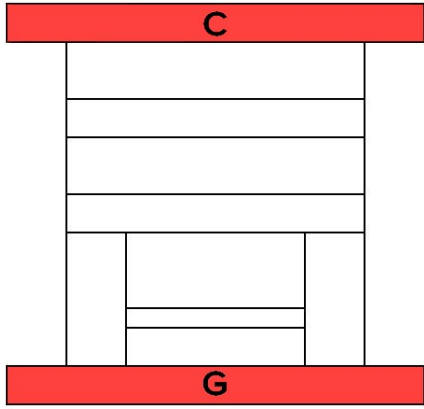

| |
|-------|
| C - G |
| 27 |

Material - Mild Steel

DIE PLATE

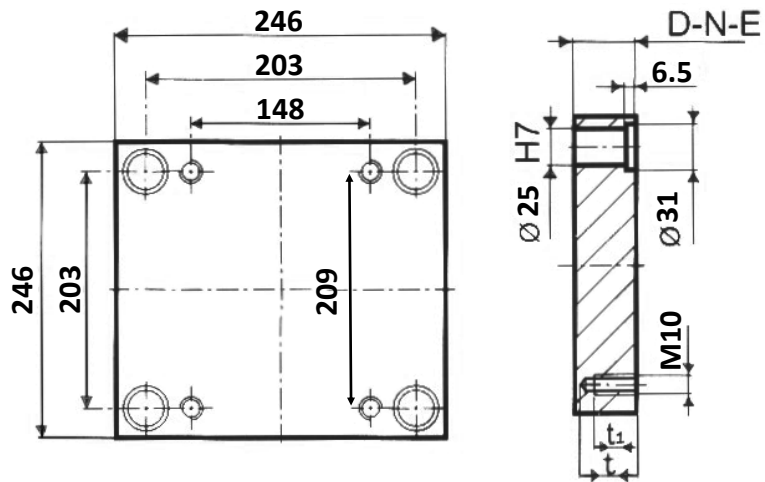
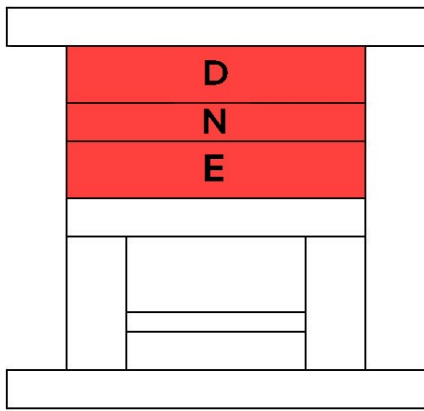

| | | |
|-------|----|----|
| D-N-E | | |
| 22 | 27 | 36 |
| 46 | 56 | 76 |

Material - 2312

| | | |
|----------------|--------|----|
| t ₁ | DNE=22 | 15 |
| | DNE>22 | 18 |
| t | DNE=22 | 20 |
| | DNE>22 | 25 |

SUPPORT

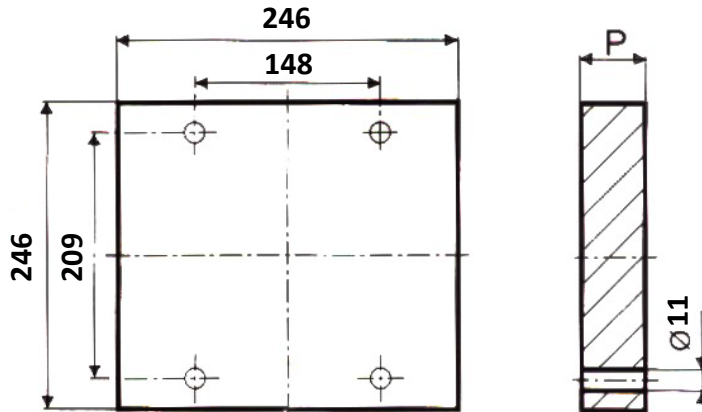
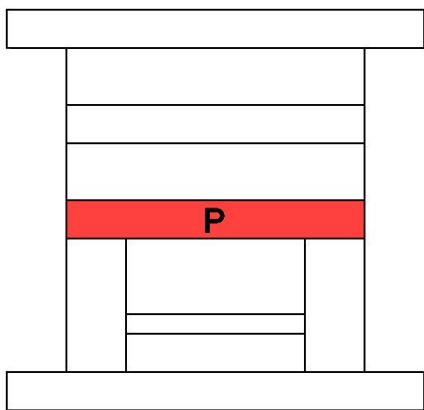

| |
|----|
| P |
| 27 |

Material - Mild Steel

RISERS

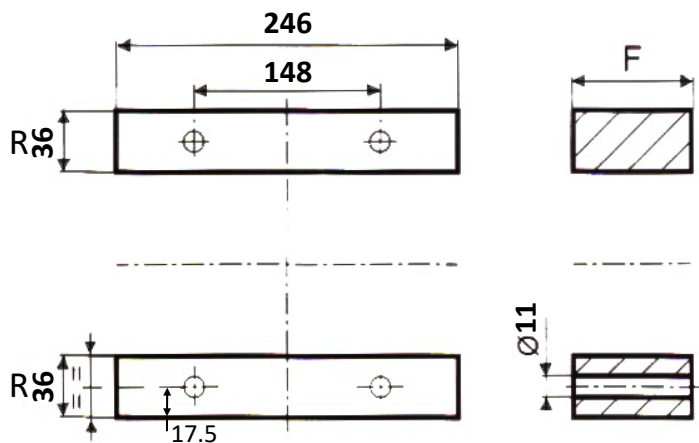
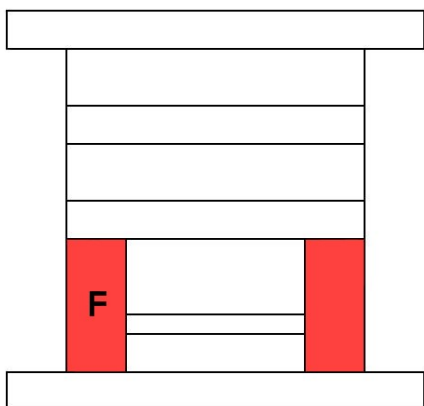

| | | |
|----|----|----|
| F | | |
| 50 | 60 | 70 |

Material - Mild Steel

| |
|----|
| R |
| 36 |

CLAMP PLATE

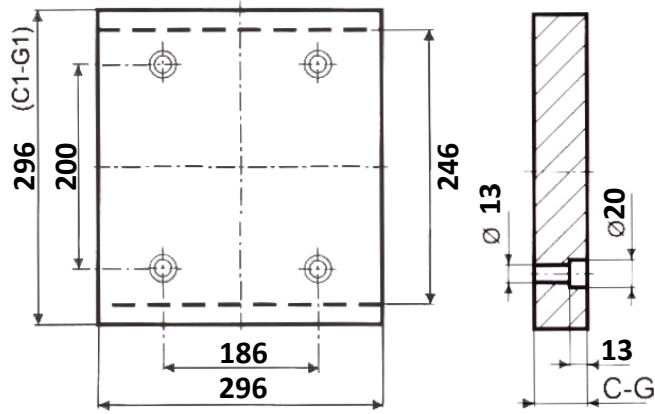
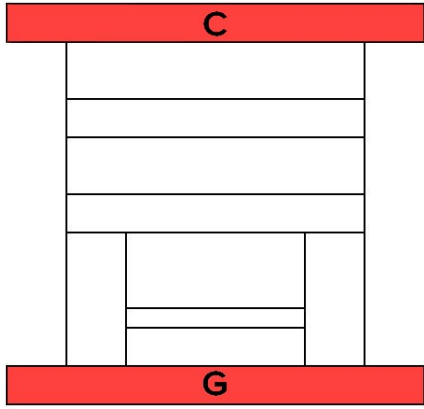

| |
|--------------|
| C - G |
| 27 |

Material - Mild Steel

DIE PLATE

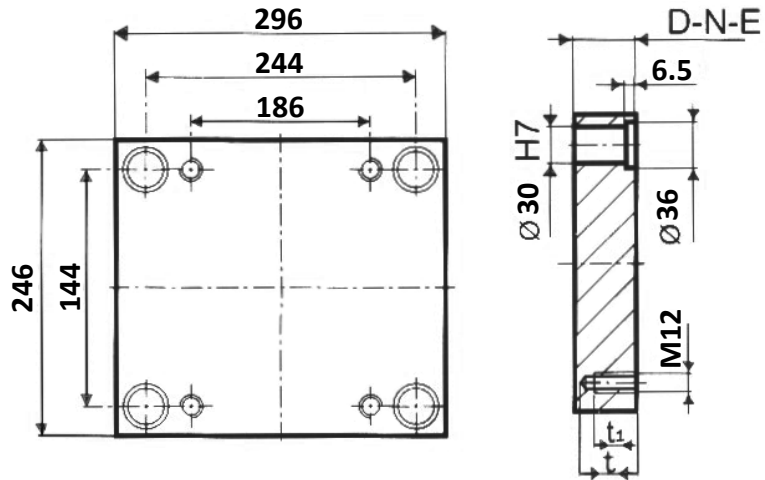
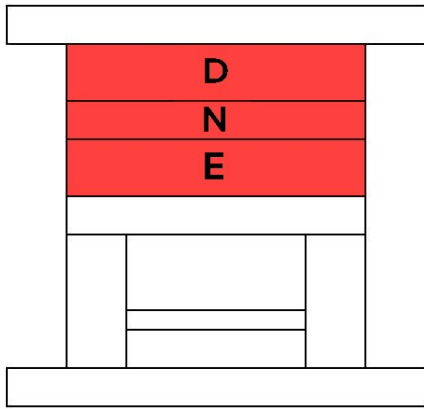

| | | |
|--------------|-----------|-----------|
| D-N-E | | |
| 22 | 27 | 36 |
| 46 | 56 | 76 |

Material - 2312

| | | |
|----------------|--------|----|
| t ₁ | DNE=22 | 15 |
| | DNE>22 | 18 |
| t | DNE=22 | 20 |
| | DNE>22 | 25 |

SUPPORT

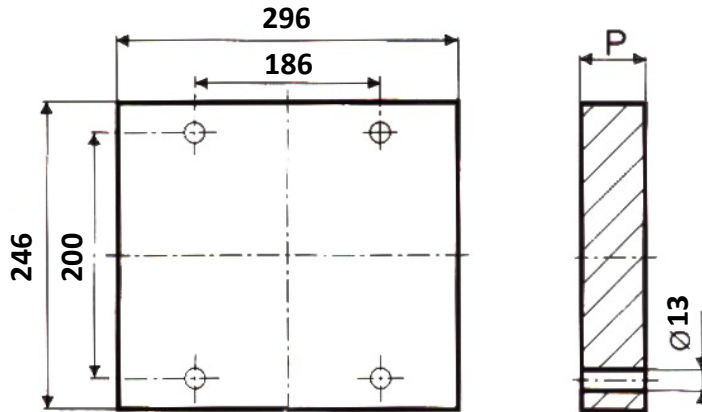
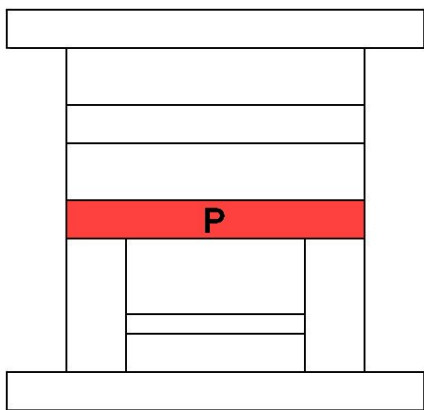

| |
|-----------|
| P |
| 27 |

Material - Mild Steel

RISERS

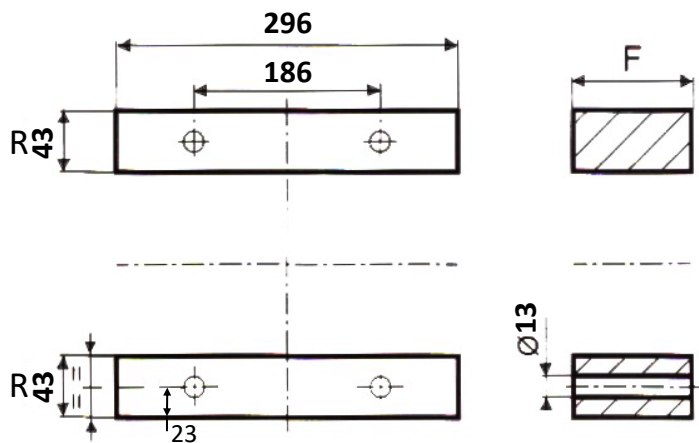
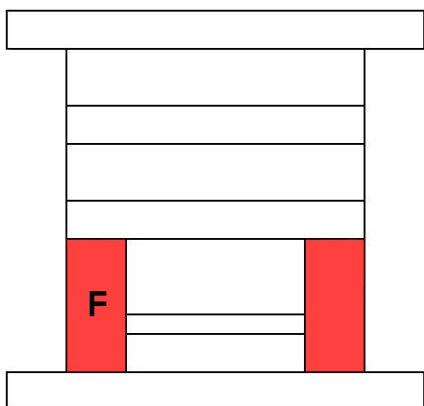

| | | |
|-----------|-----------|-----------|
| F | | |
| 50 | 60 | 70 |

Material - Mild Steel

| |
|-----------|
| R |
| 43 |



246 x 346

DIE

CLAMP PLATE

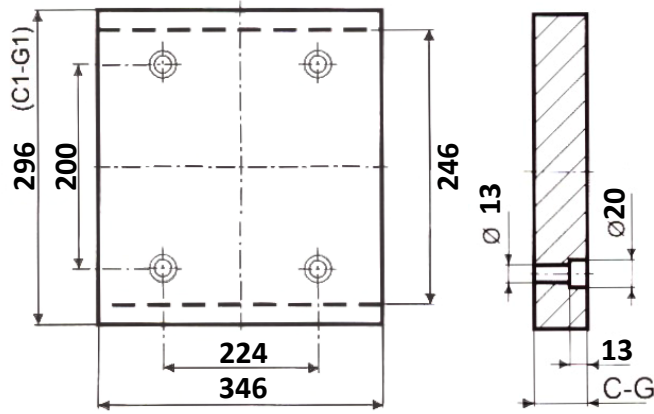
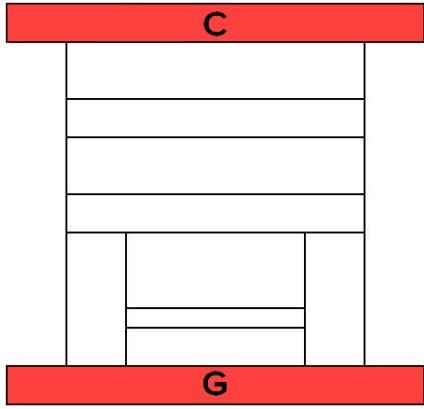

| |
|--------------|
| C - G |
| 27 or 36 |

Material - Mild Steel

DIE PLATE

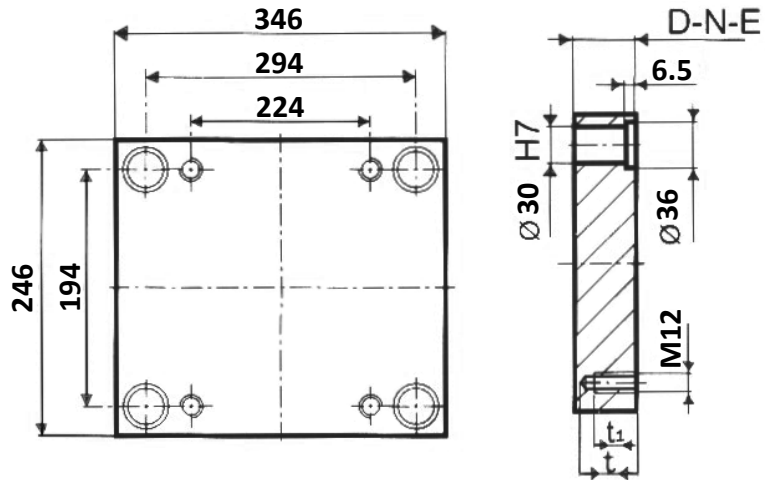
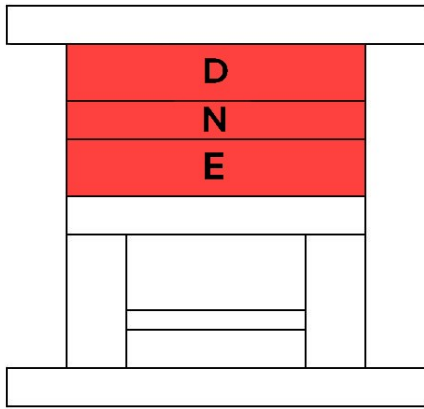

| | | |
|--------------|----|----|
| D-N-E | | |
| 22 | 27 | 36 |
| 46 | 56 | 76 |

Material - 2312

| | | |
|----------------|--------|----|
| t ₁ | DNE=22 | 15 |
| | DNE>22 | 18 |
| t | DNE=22 | 20 |
| | DNE>22 | 25 |

SUPPORT

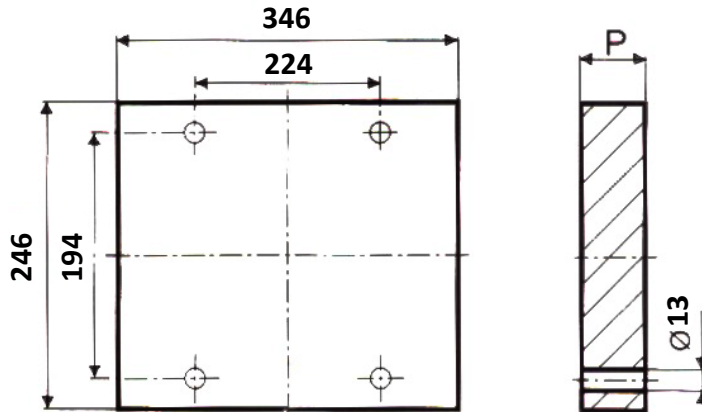
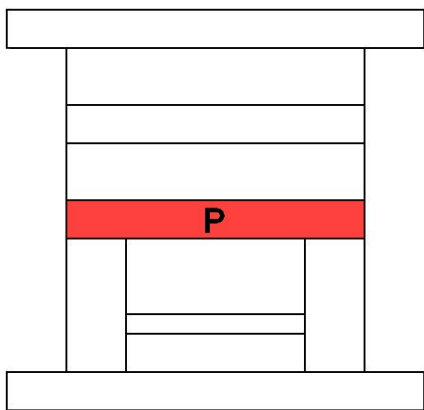

| |
|----------|
| P |
| 27 or 36 |

Material - Mild Steel

RISERS

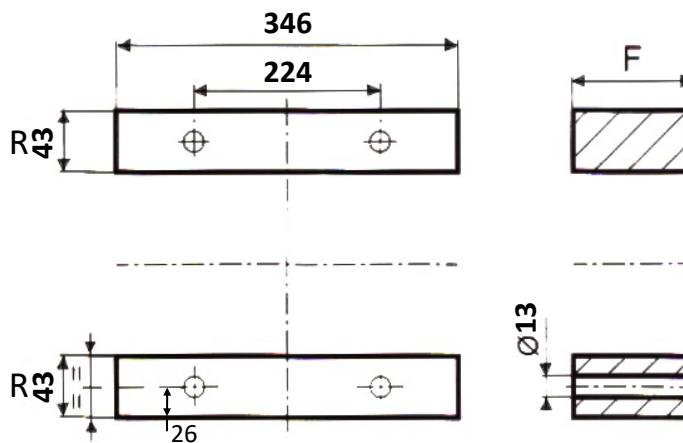
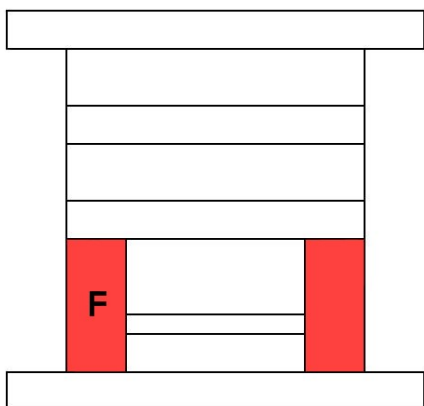

| | | |
|----------|----|----|
| F | | |
| 50 | 60 | 70 |

Material - Mild Steel

| |
|----------|
| R |
| 43 |

CLAMP PLATE

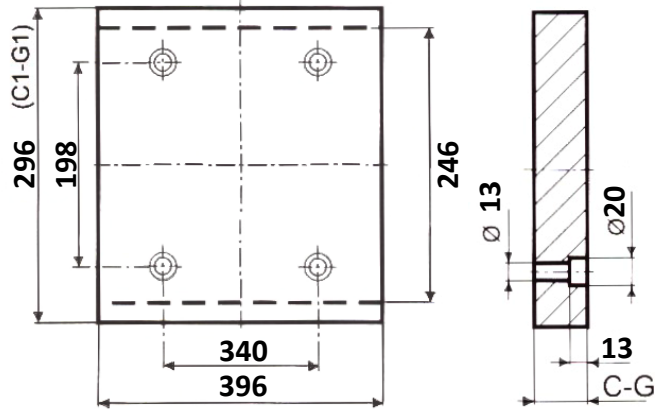
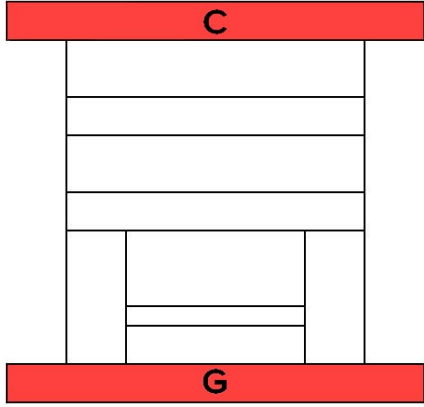

| |
|--------------|
| C - G |
| 27 or 36 |

Material - Mild Steel

DIE PLATE

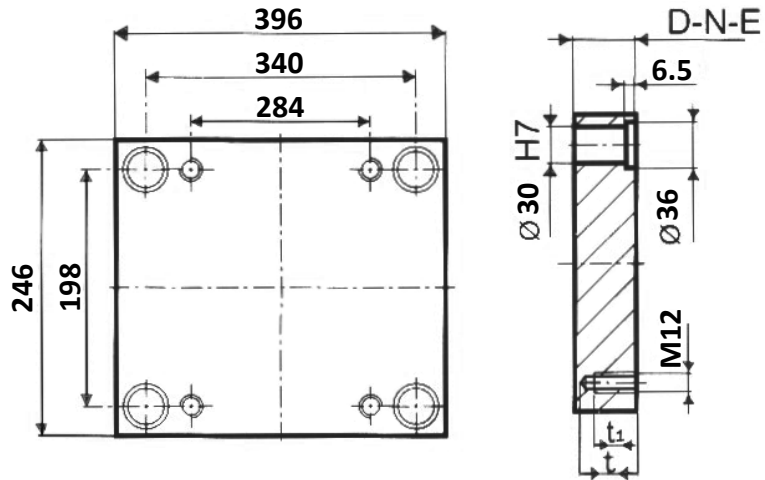
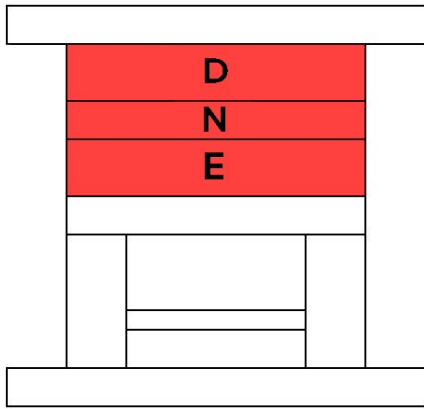

| | | |
|--------------|----|----|
| D-N-E | | |
| 22 | 27 | 36 |
| 46 | 56 | 76 |

Material - 2312

| | | |
|----------------|--------|----|
| t ₁ | DNE=22 | 15 |
| | DNE>22 | 18 |
| t | DNE=22 | 20 |
| | DNE>22 | 25 |

SUPPORT

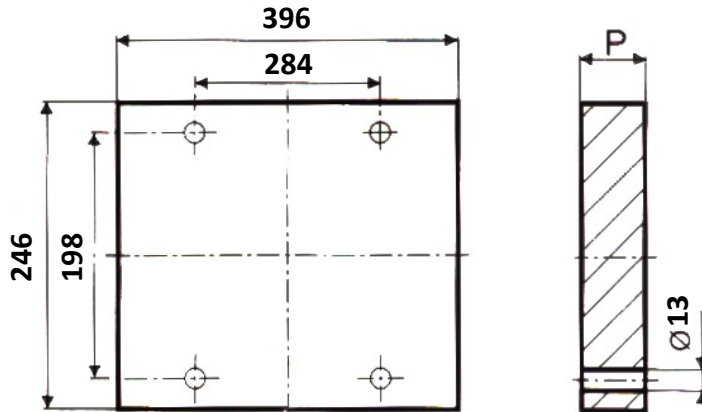
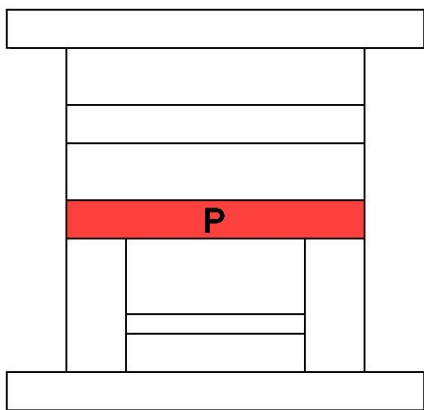

| |
|----------|
| P |
| 27 or 36 |

Material - Mild Steel

RISERS

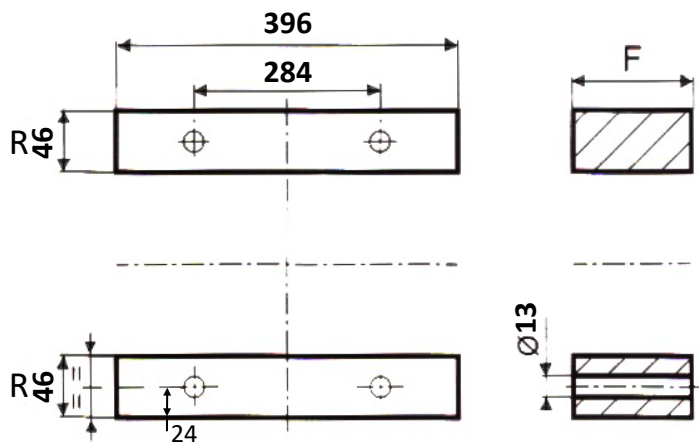
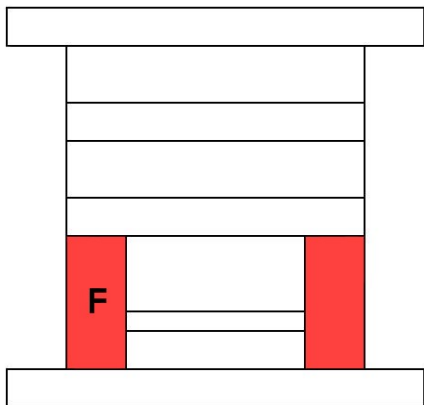

| | | |
|----------|----|----|
| F | | |
| 50 | 60 | 70 |

Material - Mild Steel

| |
|----------|
| R |
| 46 |

EJECTOR PLATES

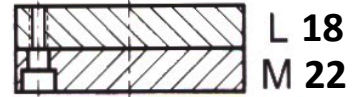
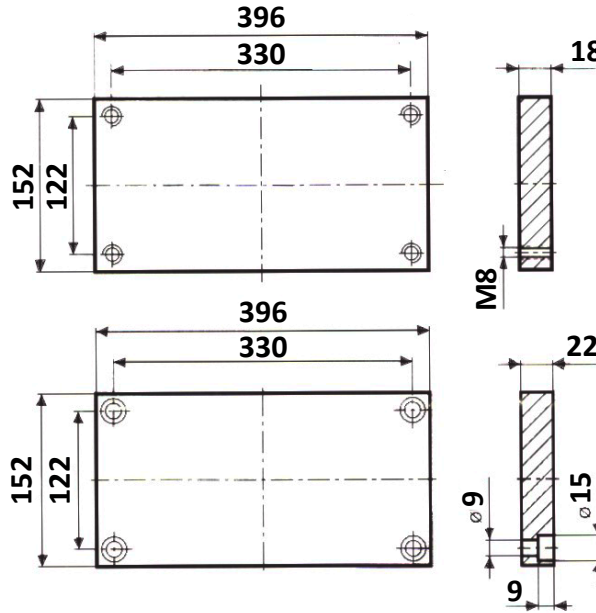
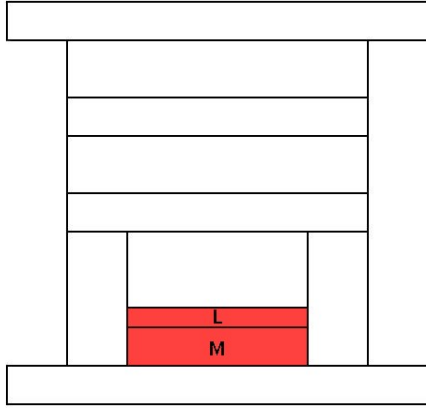

GUIDE PIN - GC

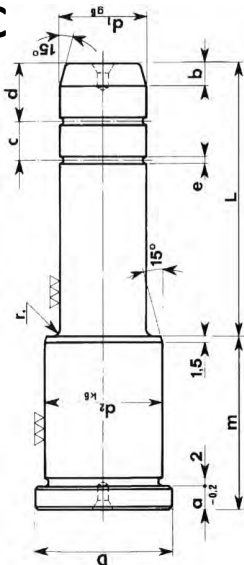

| | | D1 = 22 | | D2 = 30 | | D = 35 | | a = 6 | | |
|----|--|---------|----|---------|----|--------|-----|-------|-----|-----|
| | | L | | | | | | | | |
| m | | 36 | 45 | 50 | 70 | 100 | 125 | 150 | 175 | 200 |
| 26 | | ● | ● | | ● | ● | ● | ● | ● | |
| 34 | | ● | ● | | ● | ● | ● | ● | ● | ● |
| 44 | | ● | ● | | ● | ● | ● | ● | ● | ● |
| 54 | | ● | | ● | ● | ● | ● | ● | ● | ● |
| 74 | | ● | | ● | ● | ● | ● | ● | ● | ● |

GUIDE BUSH - CV

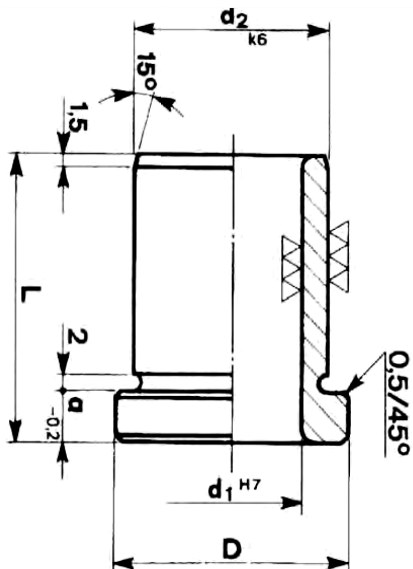

| | | D1 = 22 | | D2 = 30 | | D = 35 | | a = 6 | |
|--|--|---------|----|---------|----|--------|----|-------|--|
| | | L | | | | | | | |
| | | 26 | 35 | 45 | 55 | 65 | 75 | 95 | |
| | | ● | ● | ● | ● | ● | ● | ● | |

CLAMP PLATE

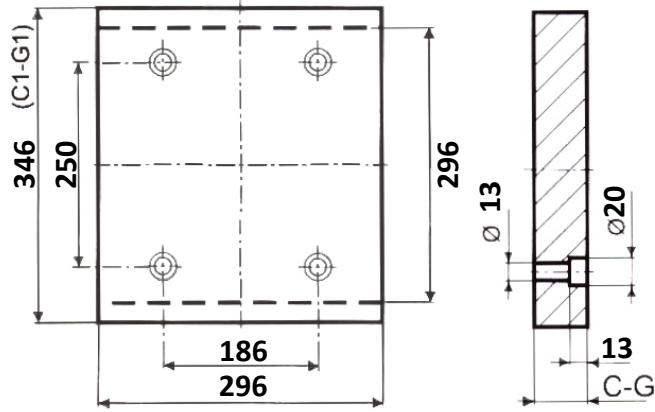
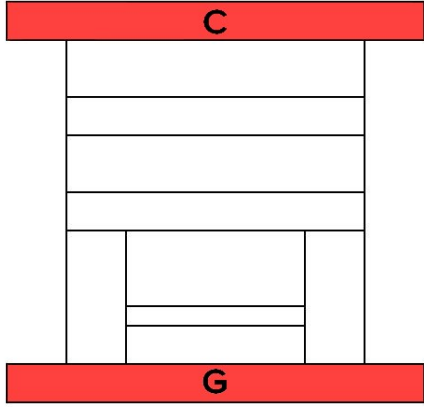

| |
|--------------|
| C - G |
| 27 or 36 |

Material - Mild Steel

DIE PLATE

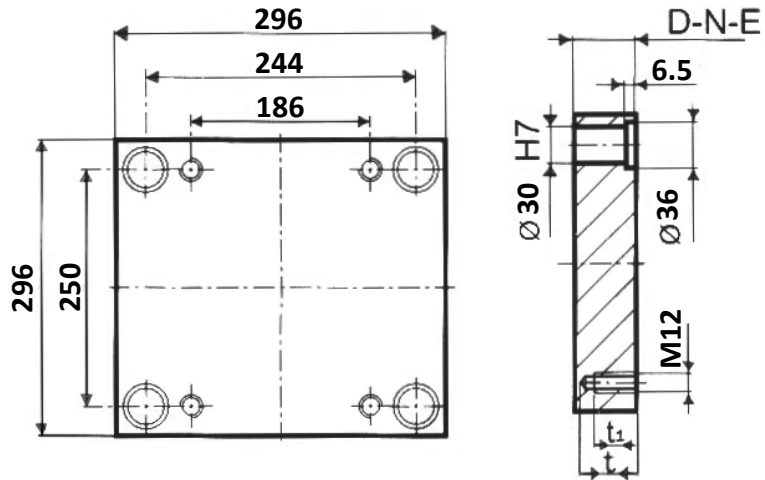
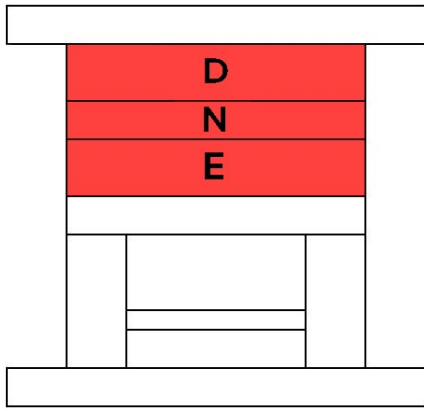

| | | |
|--------------|----|----|
| D-N-E | | |
| 22 | 27 | 36 |
| 46 | 56 | 76 |

Material - 2312

| | | |
|----------------|--------|----|
| t ₁ | DNE=22 | 15 |
| | DNE>22 | 18 |
| t | DNE=22 | 20 |
| | DNE>22 | 25 |

SUPPORT

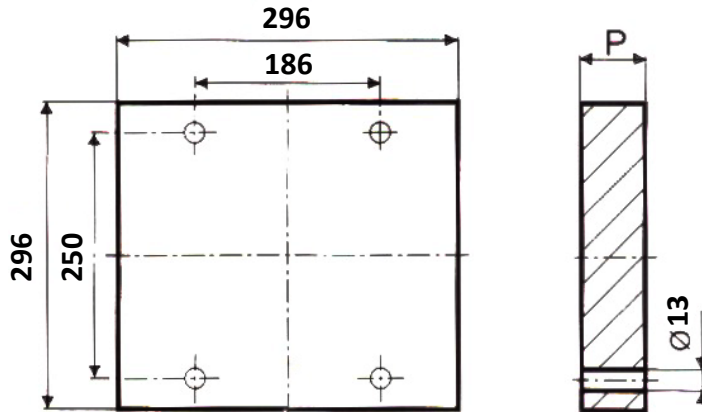
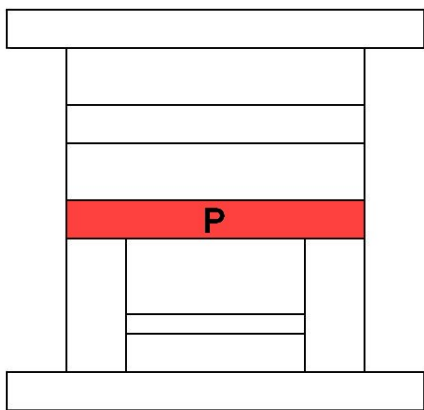

| |
|----------|
| P |
| 27 or 36 |

Material - Mild Steel

RISERS

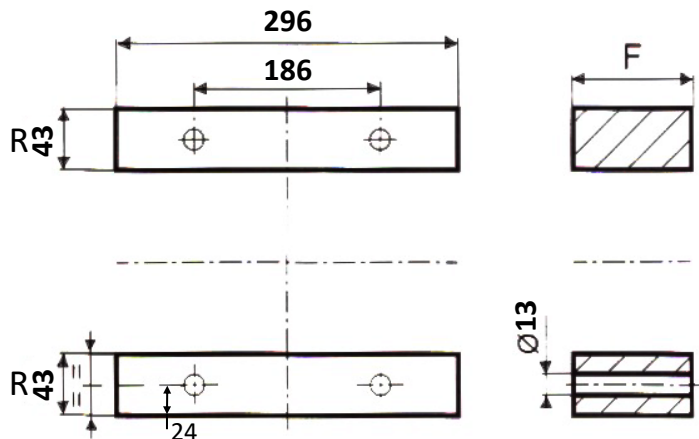
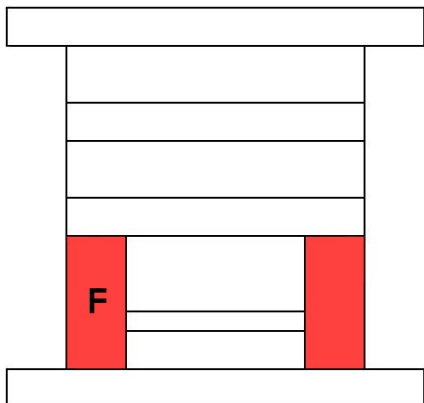

| | | |
|----------|----|----|
| F | | |
| 50 | 60 | 70 |

Material - Mild Steel

| |
|----------|
| R |
| 43 |

CLAMP PLATE

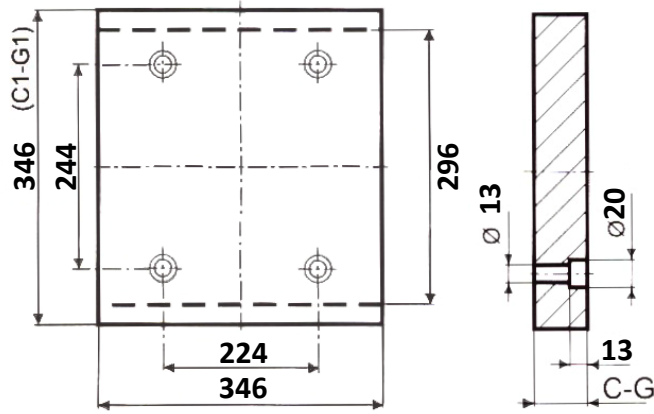
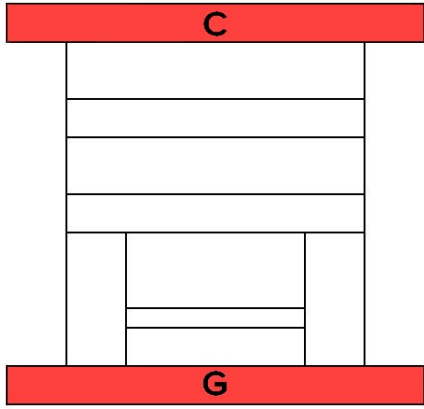

| |
|--------------|
| C - G |
| 27 or 36 |

Material - Mild Steel

DIE PLATE

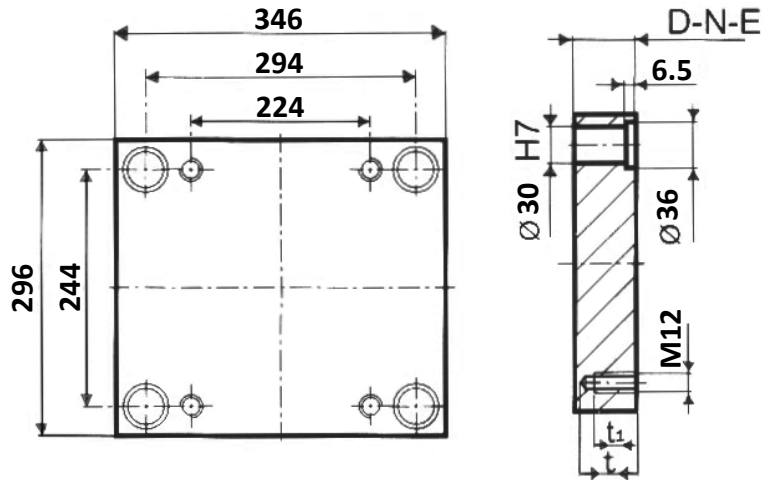
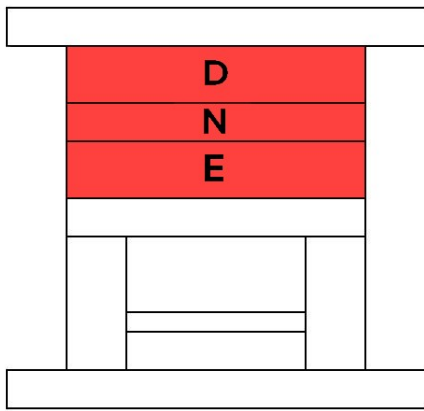

| | | |
|--------------|----|----|
| D-N-E | | |
| 22 | 27 | 36 |
| 46 | 56 | 76 |

Material - 2312

| | | |
|----------------|--------|----|
| t ₁ | DNE=22 | 15 |
| | DNE>22 | 18 |
| t | DNE=22 | 20 |
| | DNE>22 | 25 |

SUPPORT

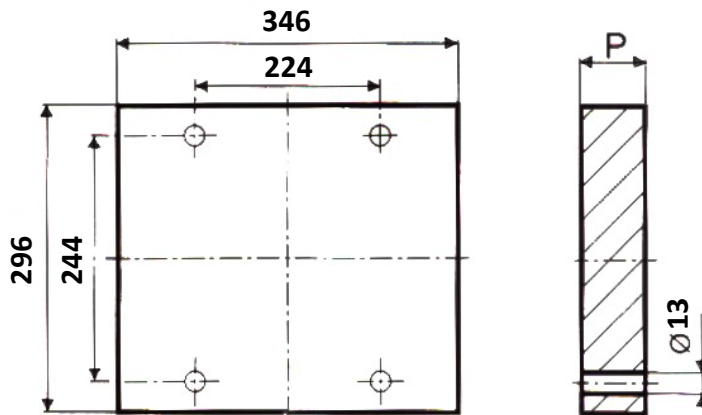
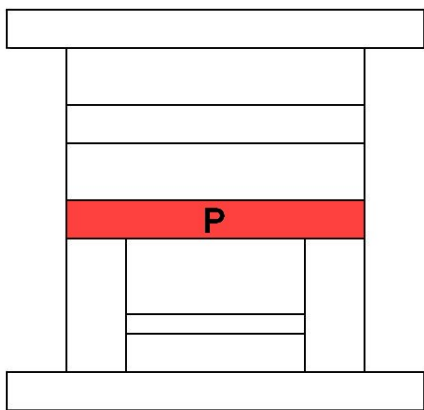

| |
|----------|
| P |
| 27 or 36 |

Material - Mild Steel

RISERS

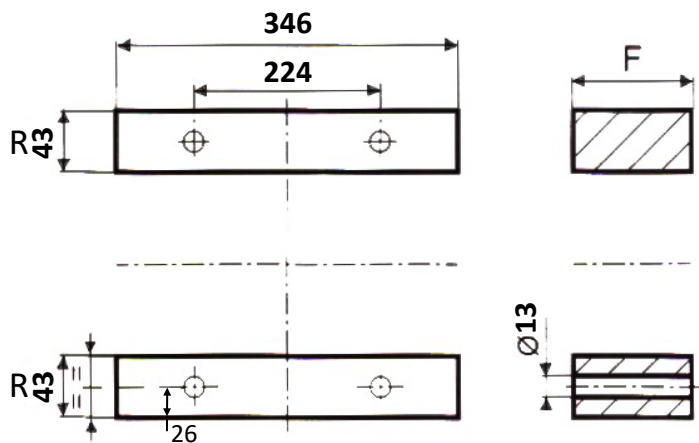
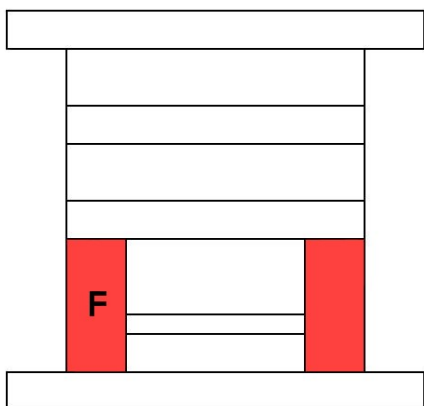

| | | |
|----------|----|----|
| F | | |
| 50 | 60 | 70 |

Material - Mild Steel

| |
|----------|
| R |
| 43 |

CLAMP PLATE

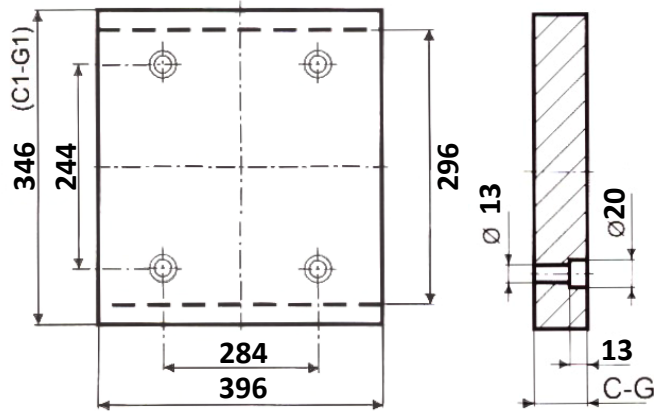
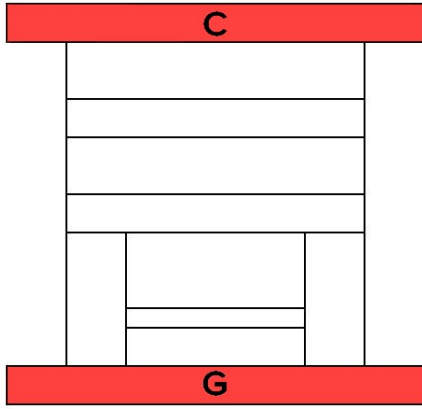

| |
|--------------|
| C - G |
| 27 or 36 |

Material - Mild Steel

DIE PLATE

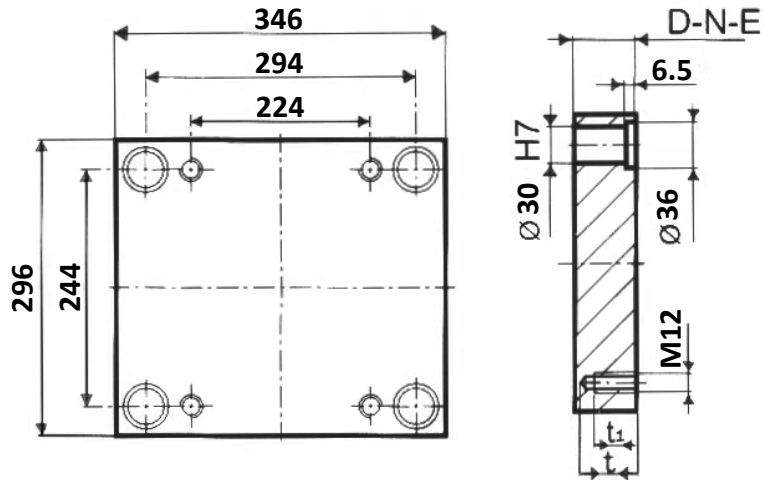
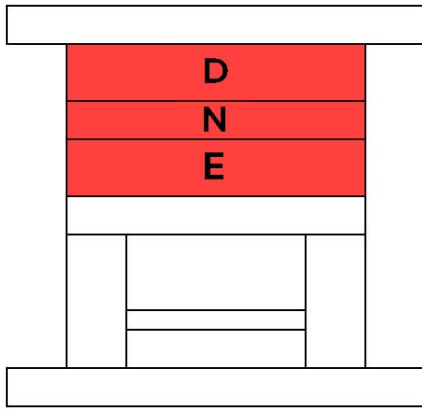

| | | |
|--------------|----|----|
| D-N-E | | |
| 22 | 27 | 36 |
| 46 | 56 | 76 |

Material - 2312

| | | |
|----------------|--------|----|
| t ₁ | DNE=22 | 15 |
| | DNE>22 | 18 |
| t | DNE=22 | 20 |
| | DNE>22 | 25 |

SUPPORT

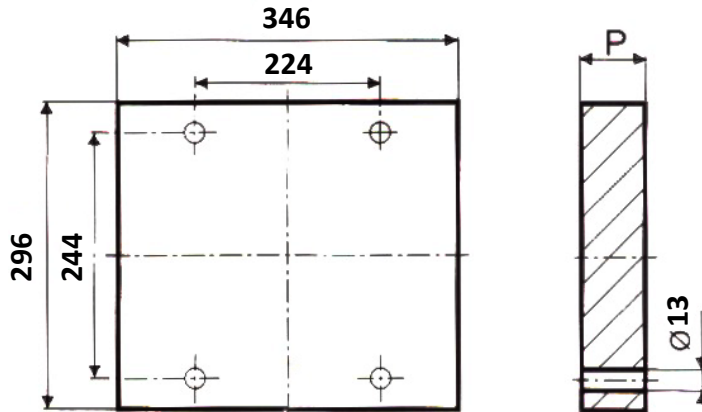
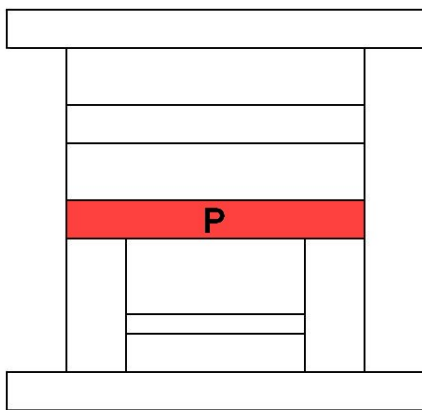

| |
|----------|
| P |
| 27 or 36 |

Material - Mild Steel

RISERS

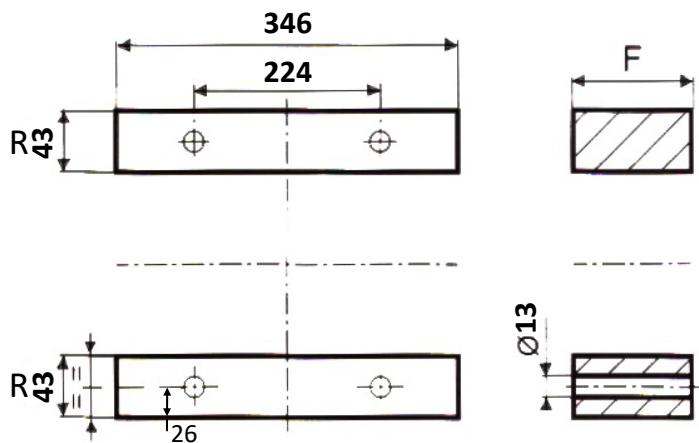
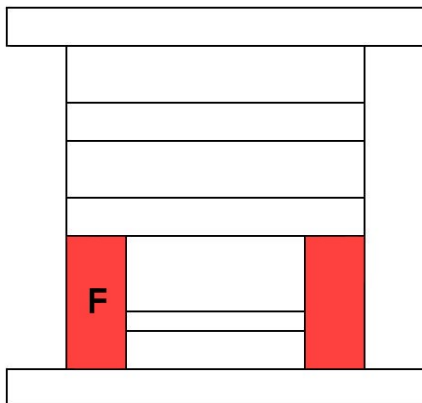

| | | |
|----------|----|----|
| F | | |
| 50 | 60 | 70 |

Material - Mild Steel

| |
|----------|
| R |
| 43 |

EJECTOR PLATES

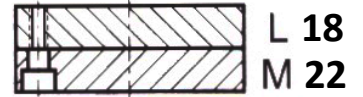
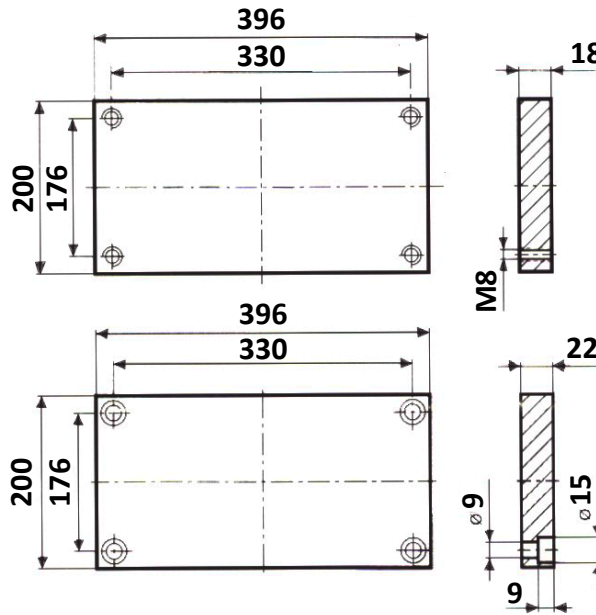
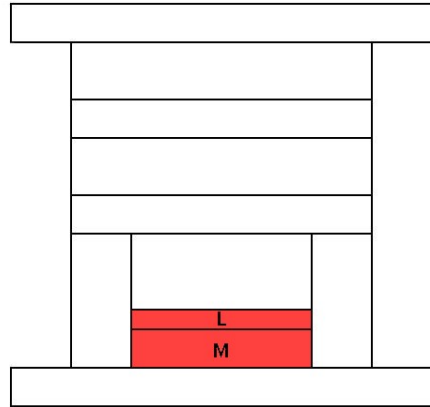

L 18
M 22

GUIDE PIN - GC

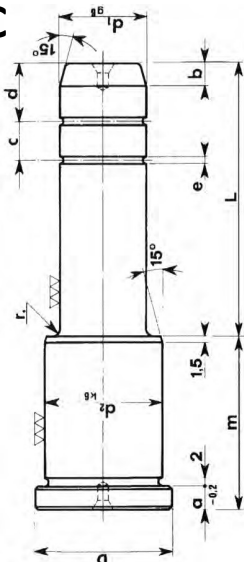

| | | D1 = 22 | | D2 = 30 | | D = 35 | | a = 6 | | |
|----|--|---------|----|---------|----|--------|-----|-------|-----|-----|
| | | L | | | | | | | | |
| m | | 36 | 45 | 50 | 70 | 100 | 125 | 150 | 175 | 200 |
| 26 | | ● | ● | | ● | ● | ● | ● | ● | |
| 34 | | ● | ● | | ● | ● | ● | ● | ● | ● |
| 44 | | ● | ● | | ● | ● | ● | ● | ● | ● |
| 54 | | ● | | ● | ● | ● | ● | ● | ● | ● |
| 74 | | ● | | ● | ● | ● | ● | ● | ● | ● |

GUIDE BUSH - CV

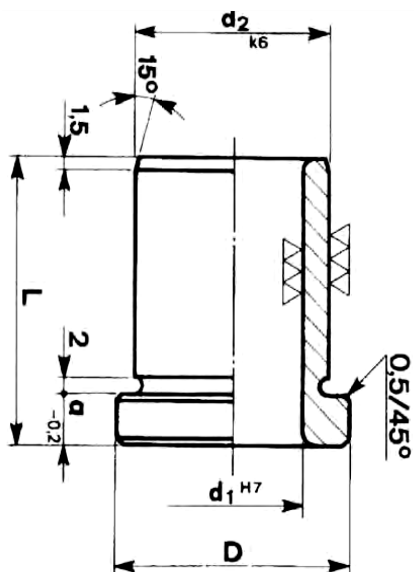

| | | D1 = 22 | | D2 = 30 | | D = 35 | | a = 6 | |
|--|--|---------|----|---------|----|--------|----|-------|--|
| | | L | | | | | | | |
| | | 26 | 35 | 45 | 55 | 65 | 75 | 95 | |
| | | ● | ● | ● | ● | ● | ● | ● | |



296 x 446

DIE

CLAMP PLATE

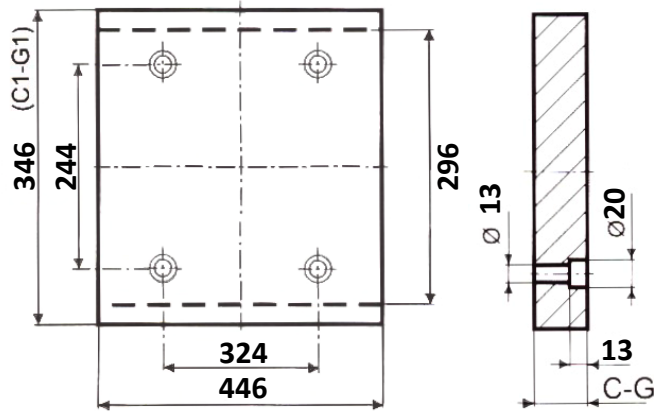
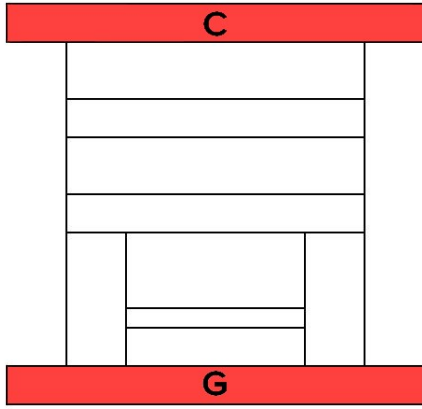

| |
|--------------|
| C - G |
| 27 or 36 |

Material - Mild Steel

DIE PLATE

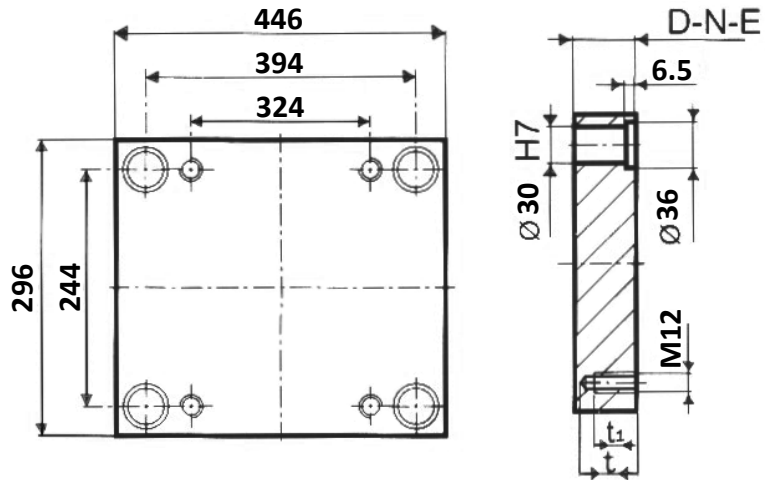
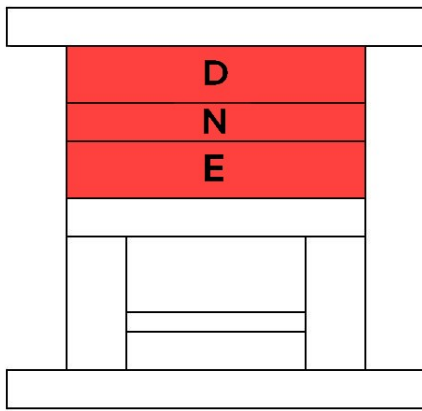

| | | |
|--------------|----|----|
| D-N-E | | |
| 22 | 27 | 36 |
| 46 | 56 | 76 |

Material - 2312

| | | |
|----------------|--------|----|
| t ₁ | DNE=22 | 15 |
| | DNE>22 | 18 |
| t | DNE=22 | 20 |
| | DNE>22 | 25 |

SUPPORT

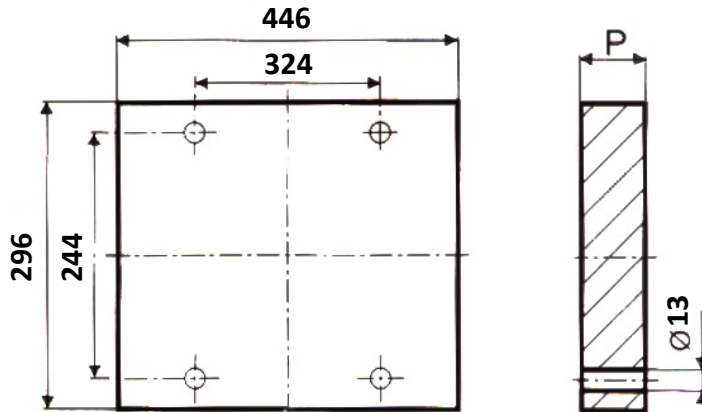
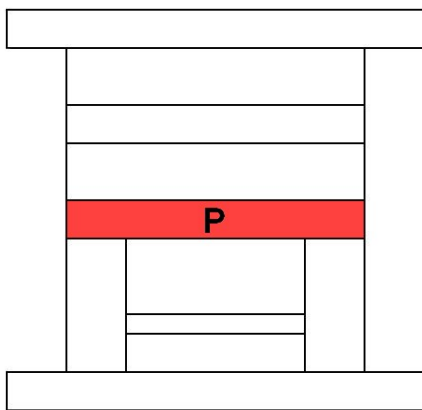

| |
|--------------|
| P |
| 27, 36 or 46 |

Material - Mild Steel

RISERS

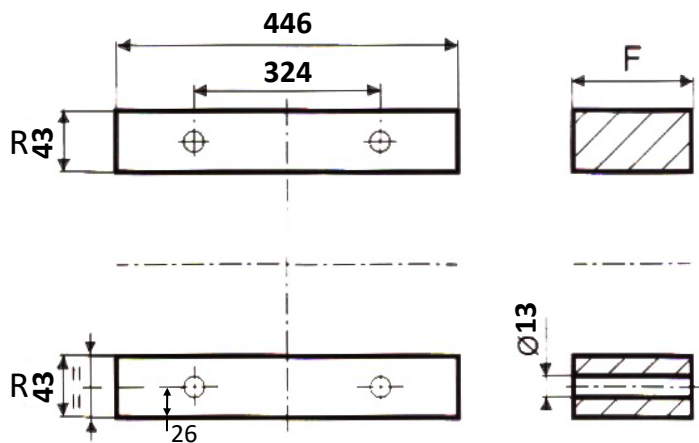
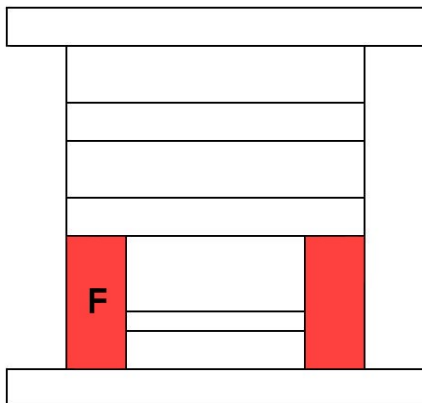

| | | |
|----------|----|----|
| F | | |
| 50 | 60 | 70 |

Material - Mild Steel

| |
|----------|
| R |
| 43 |

CLAMP PLATE

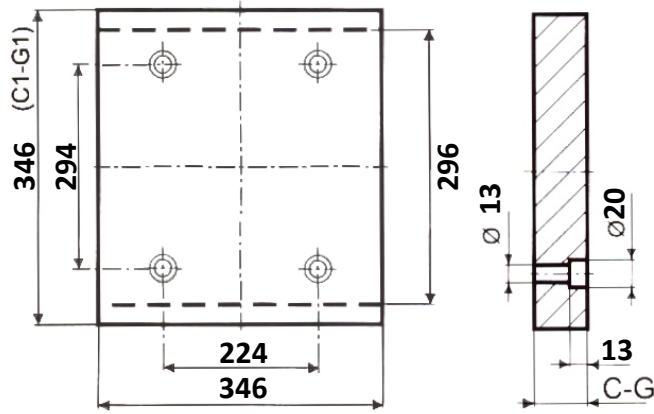
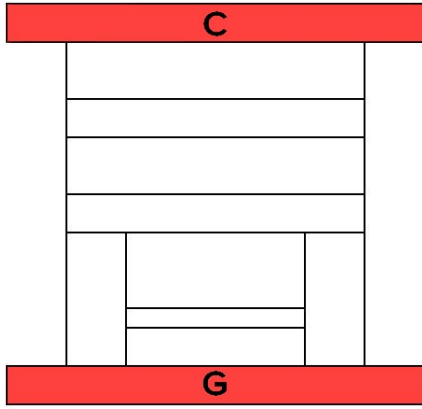

| |
|--------------|
| C - G |
| 27 or 36 |

Material - Mild Steel

DIE PLATE

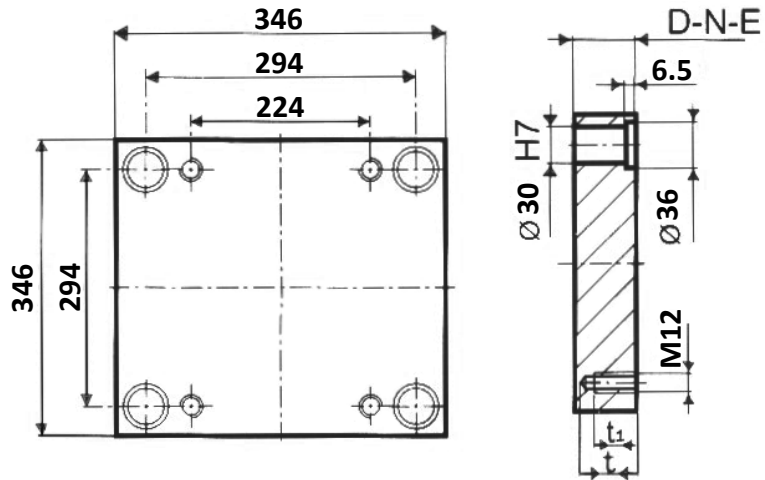
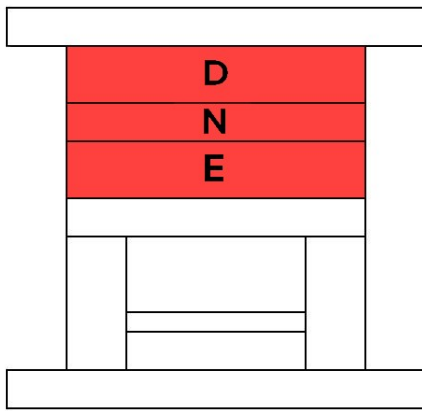

| | | |
|--------------|----|----|
| D-N-E | | |
| 22 | 27 | 36 |
| 46 | 56 | 76 |

Material - 2312

| | | |
|----------------|--------|----|
| t ₁ | DNE=22 | 15 |
| | DNE>22 | 18 |
| t | DNE=22 | 20 |
| | DNE>22 | 25 |

SUPPORT

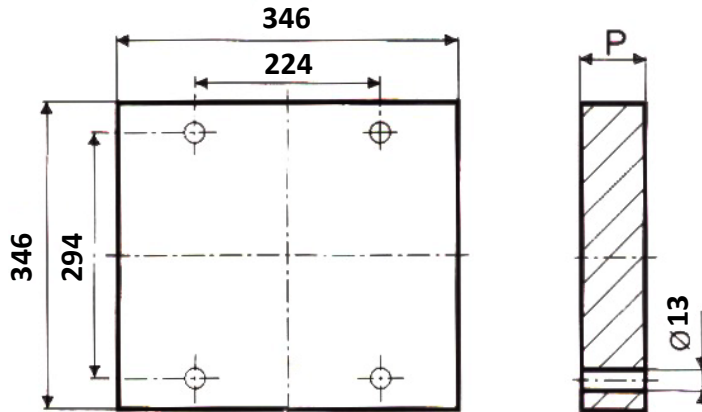
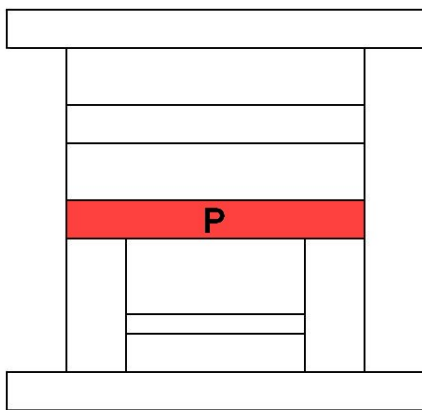

| |
|--------------|
| P |
| 27, 36 or 46 |

Material - Mild Steel

RISERS

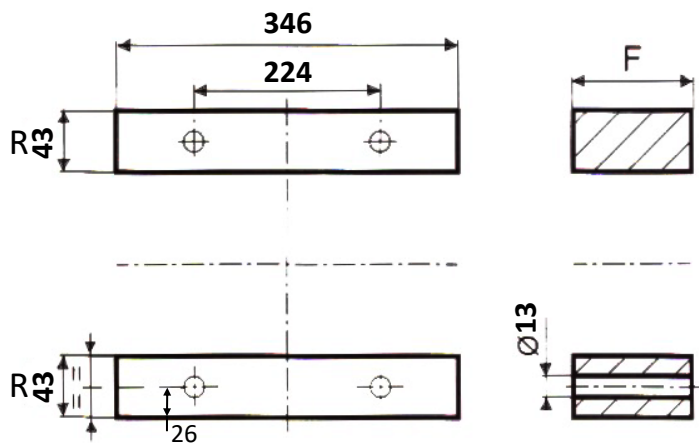
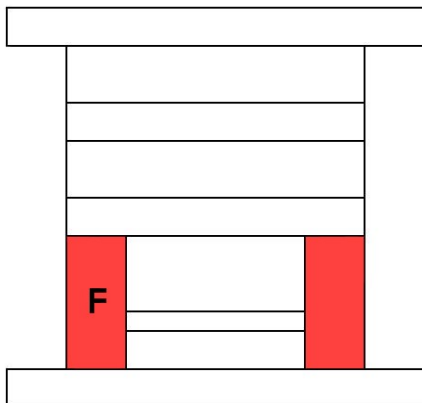

| | | |
|----------|----|----|
| F | | |
| 50 | 60 | 70 |

Material - Mild Steel

| |
|----------|
| R |
| 43 |

CLAMP PLATE

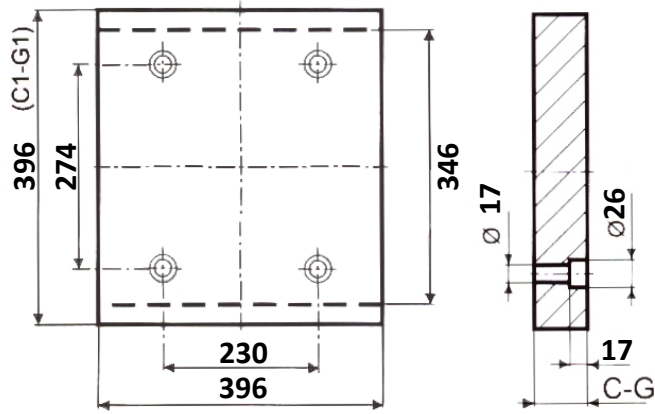
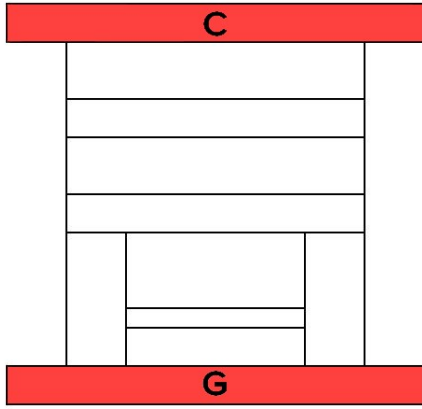

| |
|--------------|
| C - G |
| 27, 36 or 46 |

Material - Mild Steel

DIE PLATE

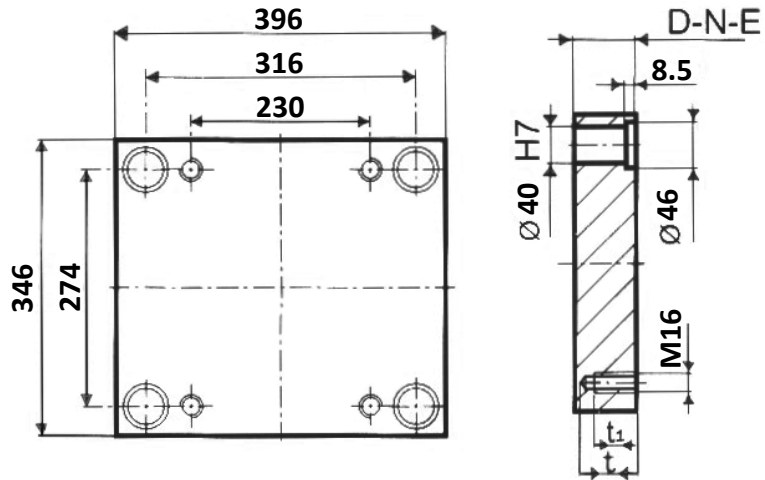
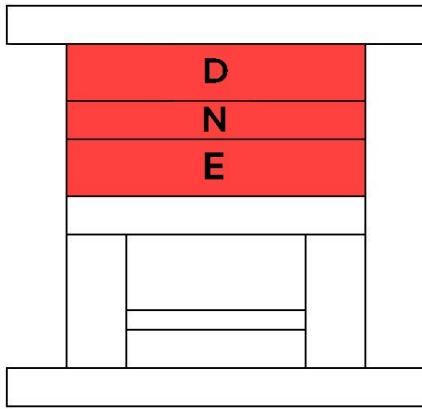

| | | |
|--------------|----|----|
| D-N-E | | |
| 22 | 27 | 36 |
| 46 | 56 | 76 |

Material - 2312

| | |
|----------------|----|
| t ₁ | 24 |
| t | 30 |

SUPPORT

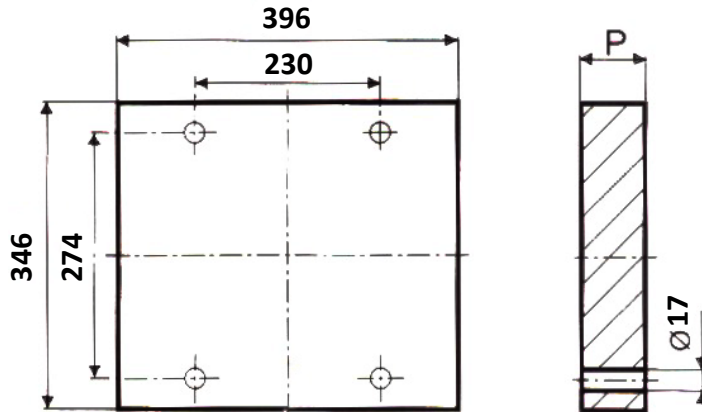
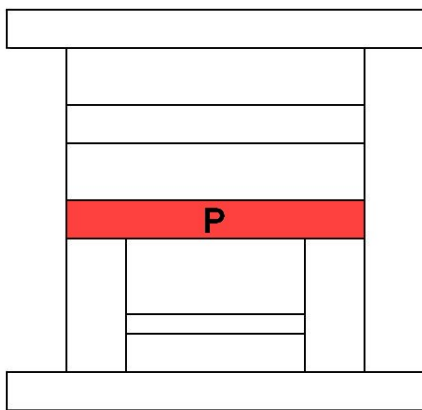

| |
|--------------|
| P |
| 27, 36 or 46 |

Material - Mild Steel

RISERS

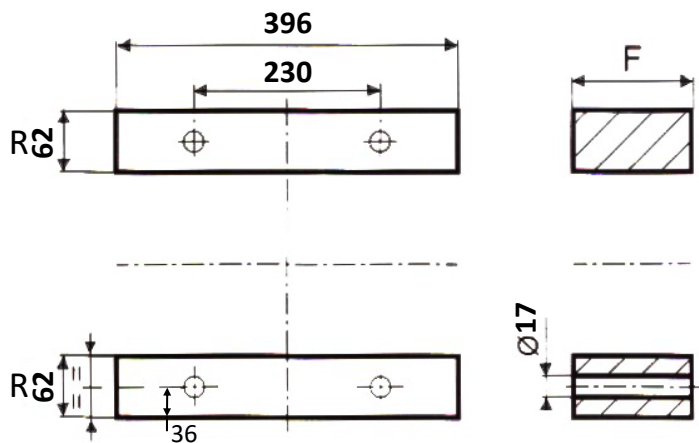
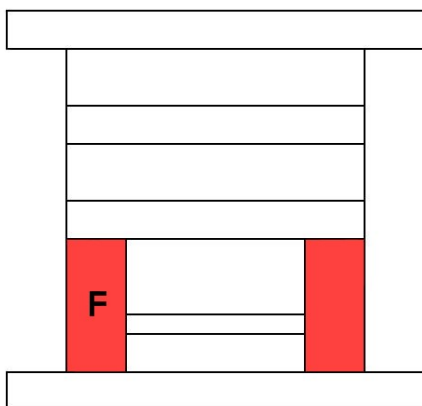

| | | |
|----------|----|----|
| F | | |
| 50 | 60 | 70 |

Material - Mild Steel

| |
|----------|
| R |
| 62 |

CLAMP PLATE

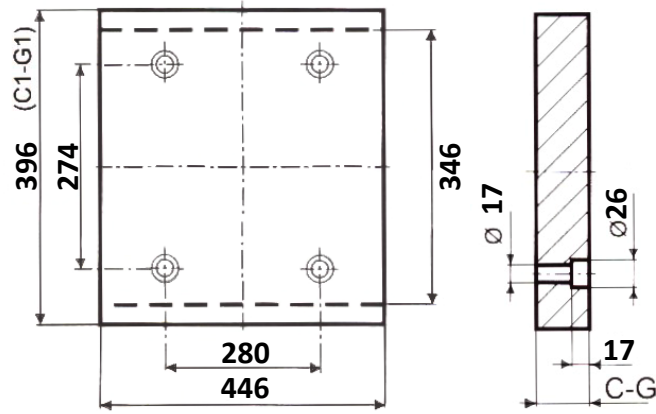
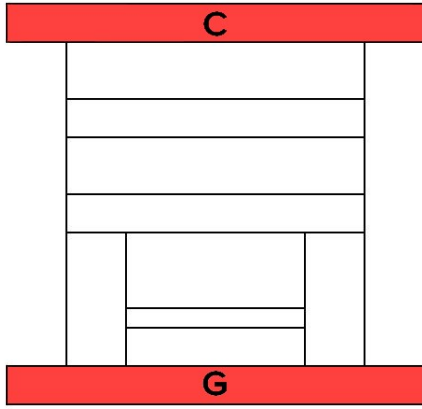

| |
|--------------|
| C - G |
| 27, 36 or 46 |

Material - Mild Steel

DIE PLATE

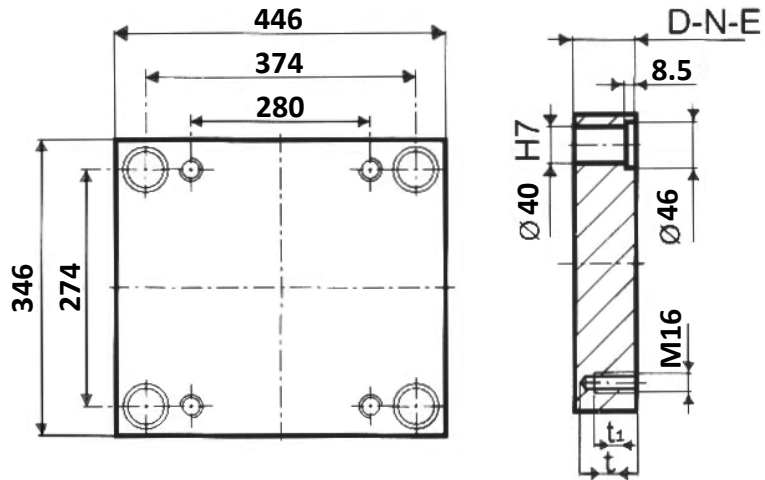
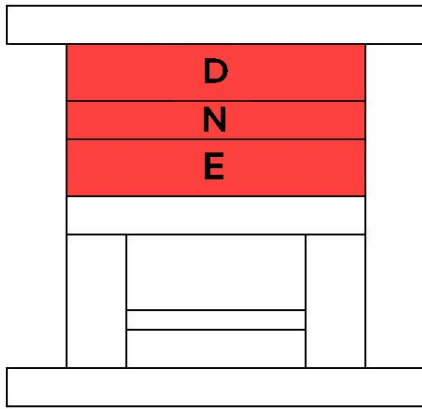

| | | |
|--------------|----|----|
| D-N-E | | |
| 22 | 27 | 36 |
| 46 | 56 | 76 |

Material - 2312

| | |
|----------------|----|
| t ₁ | 24 |
| t | 30 |

SUPPORT

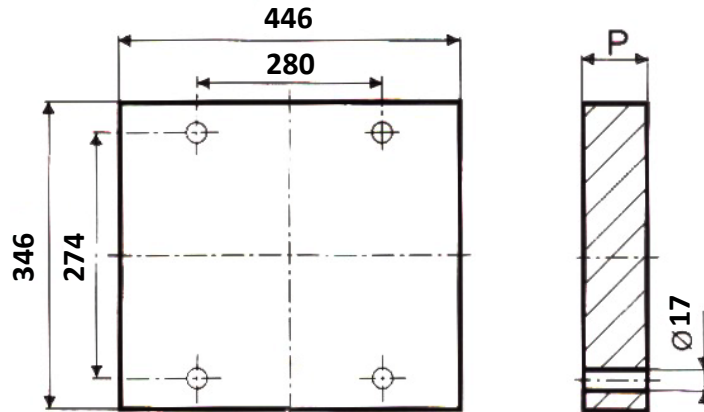
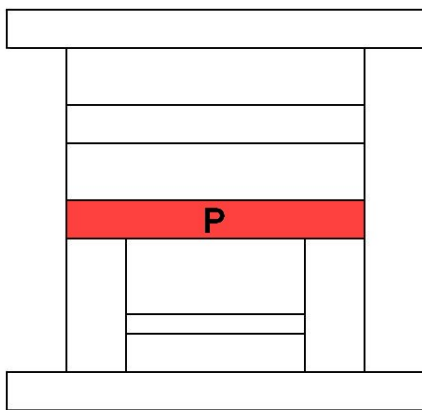

| |
|--------------|
| P |
| 27, 36 or 46 |

Material - Mild Steel

RISERS

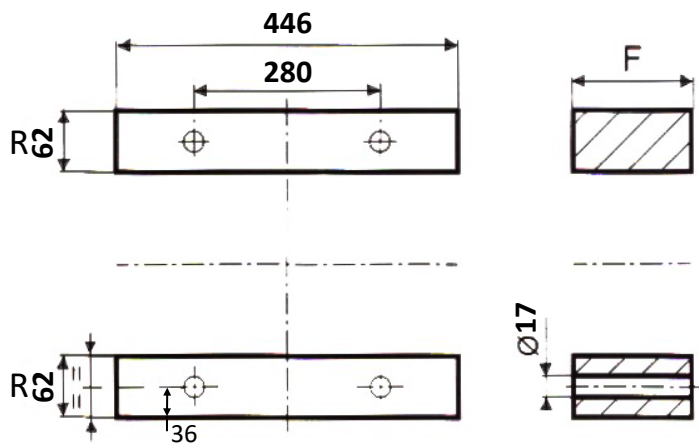
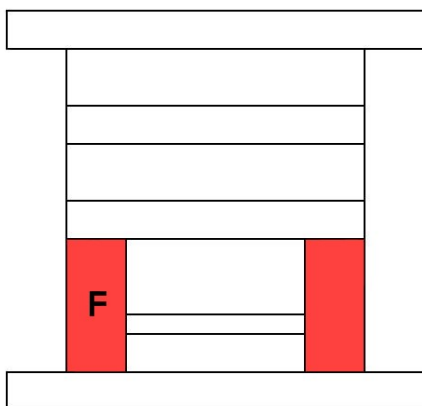

| | | |
|----------|----|----|
| F | | |
| 50 | 60 | 70 |

Material - Mild Steel

| |
|----------|
| R |
| 62 |

EJECTOR PLATES

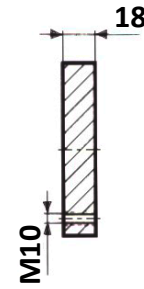
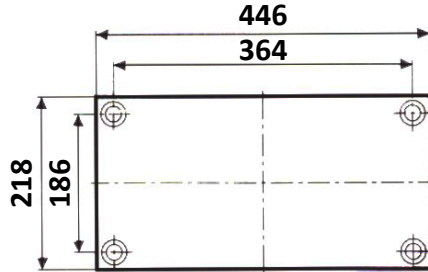
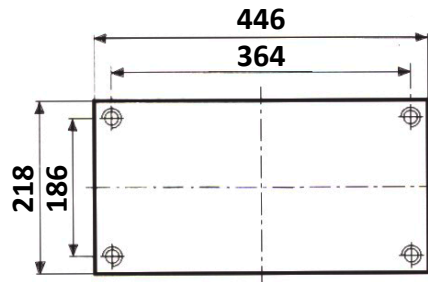
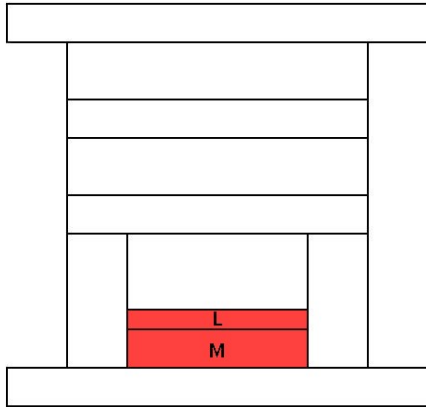

L 18
M 22

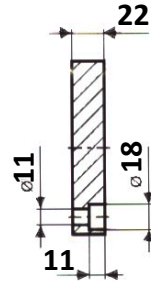

GUIDE PIN - GC

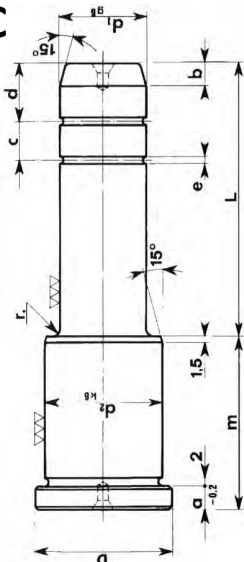

| | | D1 = 30 | | D2 = 40 | | D = 46 | | a = 8 | | |
|----|----|---------|----|---------|----|--------|-----|-------|-----|-----|
| m | L | | | | | | | | | |
| | 36 | 45 | 50 | 70 | 90 | 100 | 125 | 150 | 175 | 200 |
| 26 | ● | ● | | ● | | ● | ● | ● | | |
| 34 | ● | ● | | ● | | ● | ● | ● | ● | ● |
| 44 | | ● | | ● | ● | | ● | ● | ● | ● |
| 54 | ● | | ● | ● | | ● | ● | ● | ● | ● |
| 74 | ● | | ● | ● | | ● | ● | ● | ● | ● |

GUIDE BUSH - CV

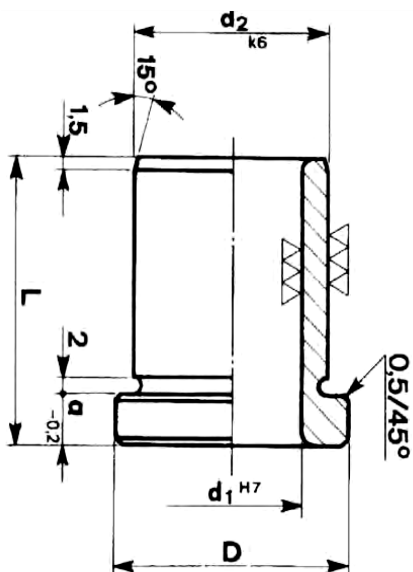

| | | D1 = 30 | | D2 = 40 | | D = 48 | | a = 8 | |
|----|----|---------|----|---------|----|--------|--|-------|--|
| | | L | | | | | | | |
| 26 | 35 | 45 | 55 | 65 | 75 | 95 | | | |
| ● | ● | ● | ● | ● | ● | ● | | | |

CLAMP PLATE

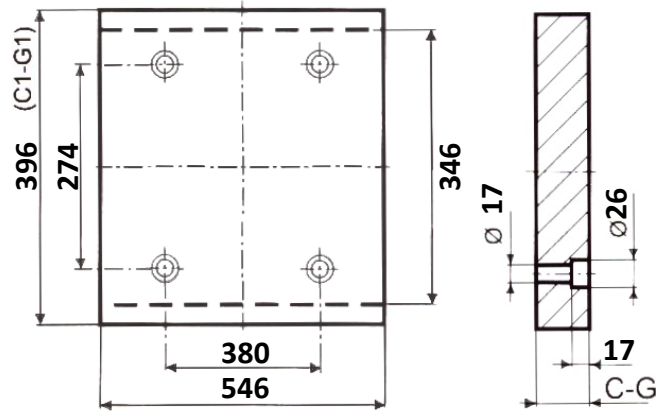
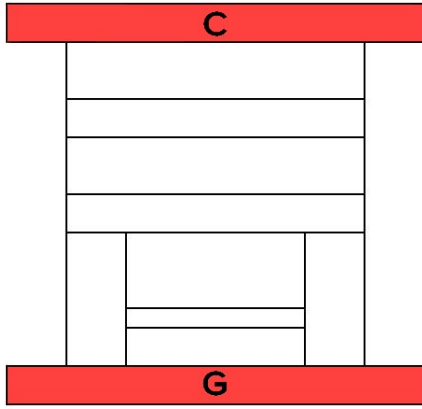

| |
|--------------|
| C - G |
| 36 or 46 |

Material - Mild Steel

DIE PLATE

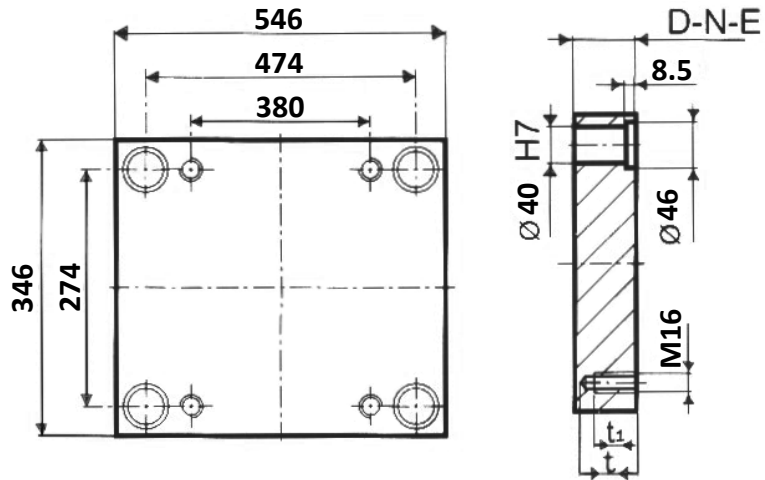
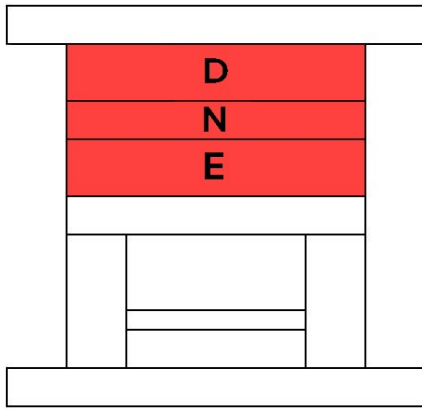

| | | |
|--------------|----|----|
| D-N-E | | |
| 22 | 27 | 36 |
| 46 | 56 | 76 |

Material - 2312

| | |
|----------------|----|
| t ₁ | 24 |
| t | 30 |

SUPPORT

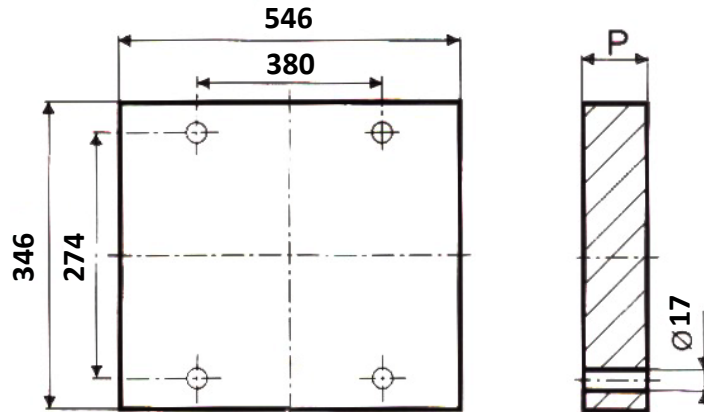
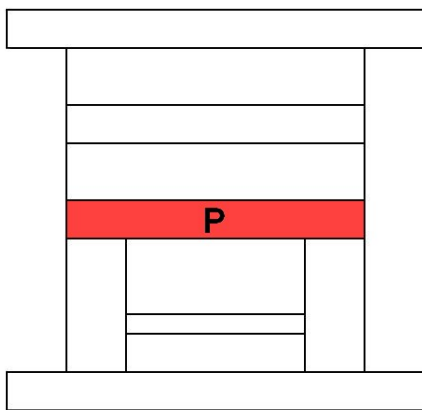

| |
|----------|
| P |
| 36 or 46 |

Material - Mild Steel

RISERS

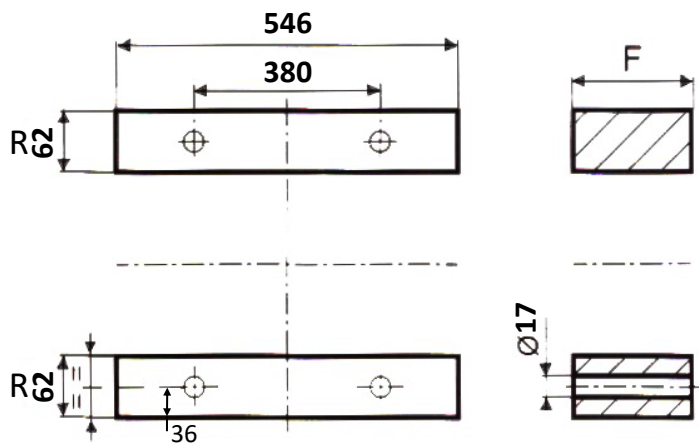
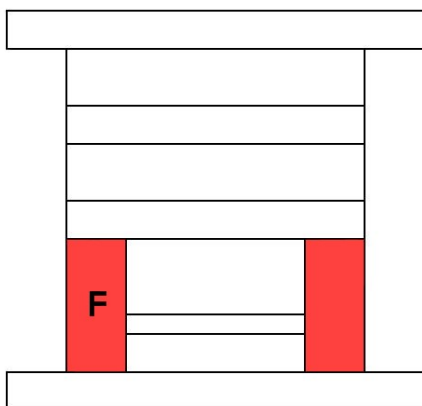

| | | |
|----------|----|----|
| F | | |
| 50 | 60 | 70 |

Material - Mild Steel

| |
|----------|
| R |
| 62 |

CLAMP PLATE

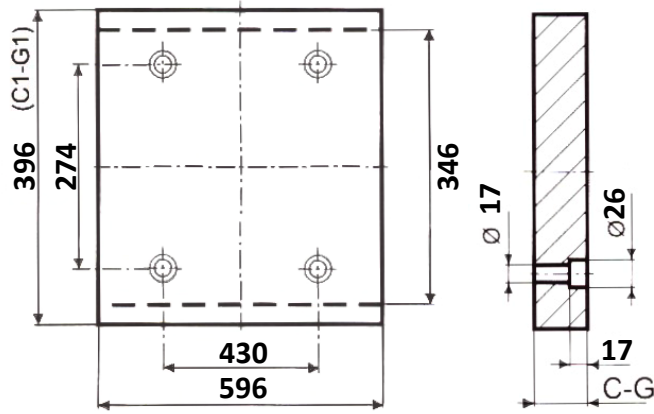
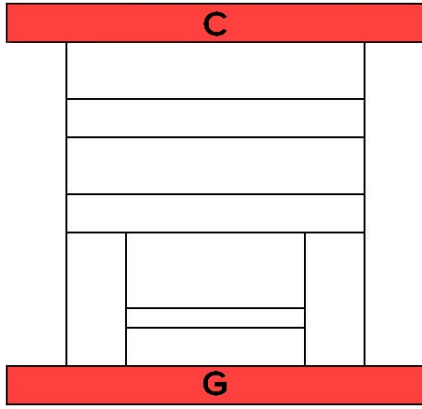

| |
|--------------|
| C - G |
| 36 or 46 |

Material - Mild Steel

DIE PLATE

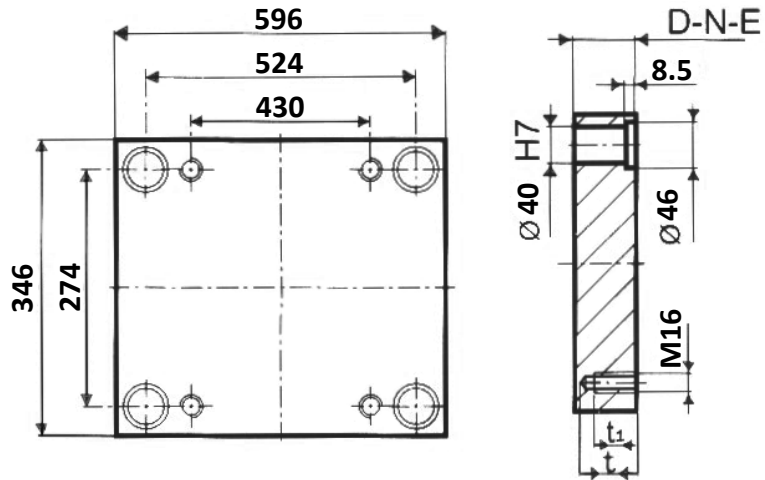
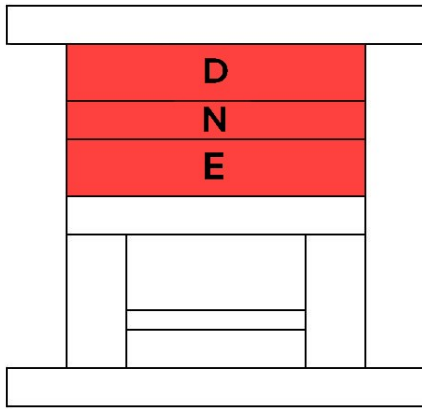

| | | |
|--------------|----|----|
| D-N-E | | |
| 22 | 27 | 36 |
| 46 | 56 | 76 |

Material - 2312

| | |
|----------------|----|
| t ₁ | 24 |
| t | 30 |

SUPPORT

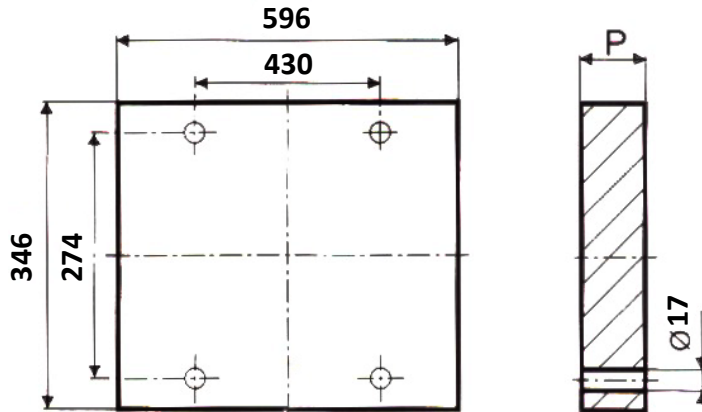
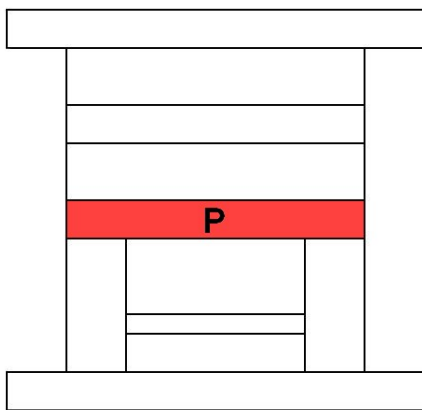

| |
|----------|
| P |
| 36 or 46 |

Material - Mild Steel

RISERS

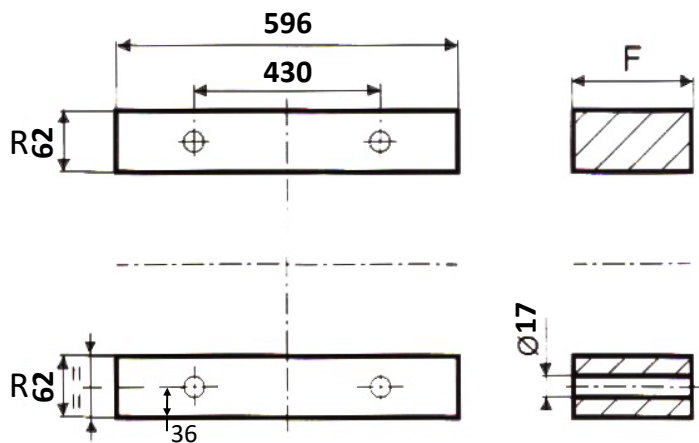
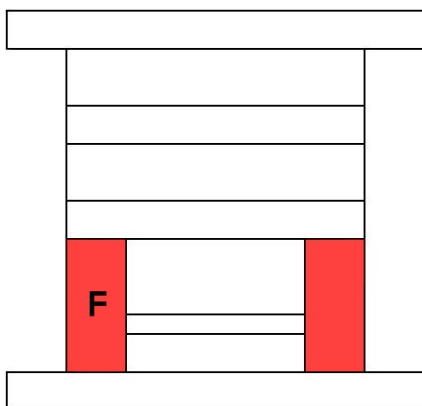

| | | |
|----------|----|----|
| F | | |
| 50 | 60 | 70 |

Material - Mild Steel

| |
|----------|
| R |
| 62 |

CLAMP PLATE

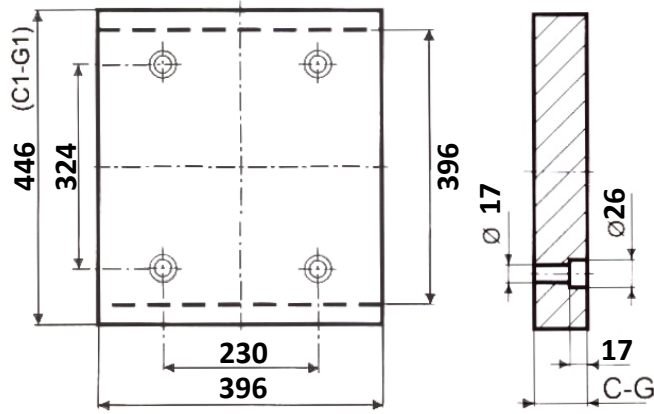
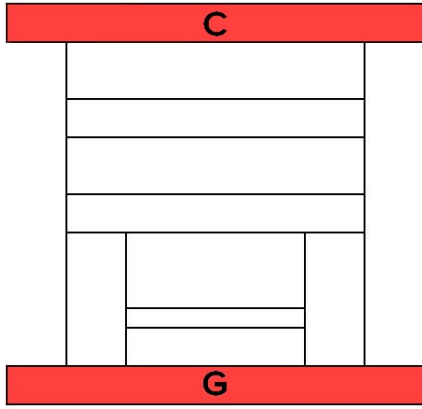

| |
|--------------|
| C - G |
| 36 or 46 |

Material - Mild Steel

DIE PLATE

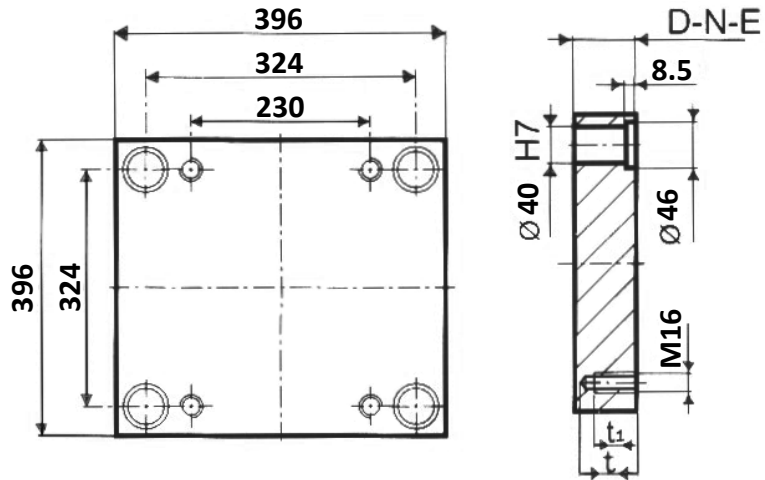
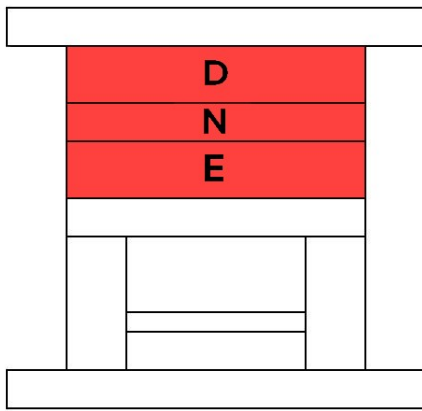

| | | |
|--------------|----|----|
| D-N-E | | |
| 22 | 27 | 36 |
| 46 | 56 | 76 |

Material - 2312

| | |
|----------------|----|
| t ₁ | 24 |
| t | 30 |

SUPPORT

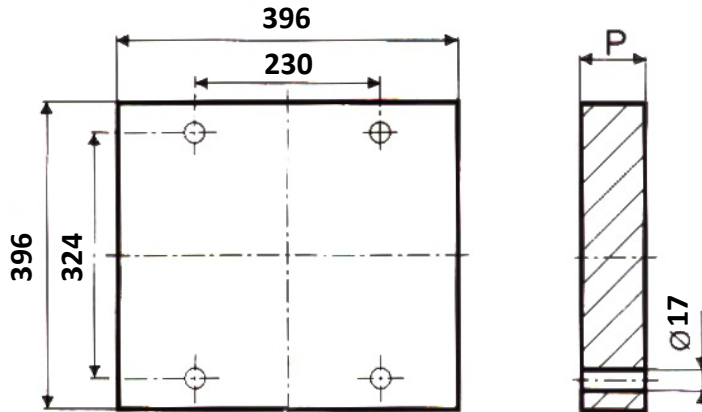
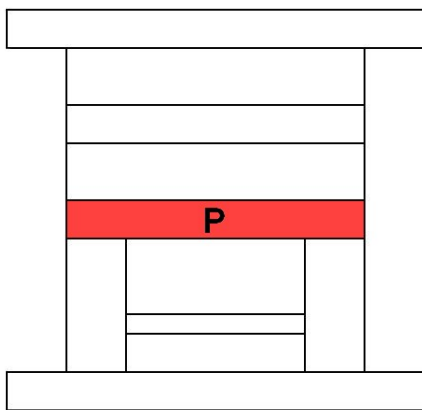

| |
|----------|
| P |
| 36 or 46 |

Material - Mild Steel

RISERS

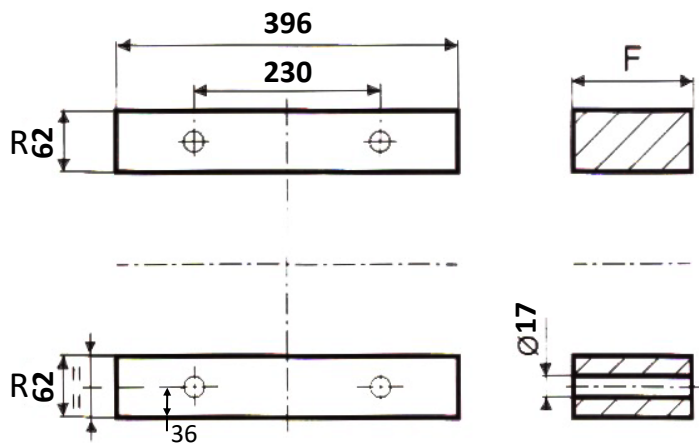
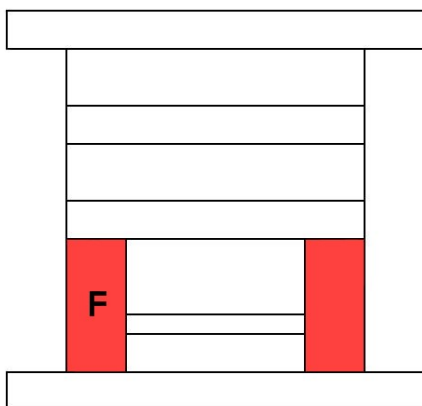

| | | |
|----------|----|----|
| F | | |
| 50 | 60 | 70 |

Material - Mild Steel

| |
|----------|
| R |
| 62 |



396 x 496

DIE

CLAMP PLATE

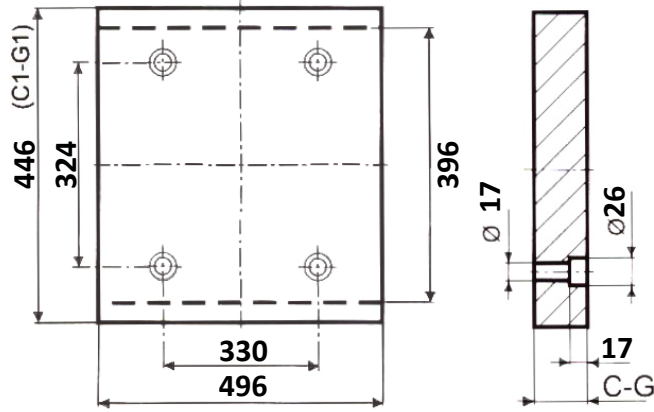
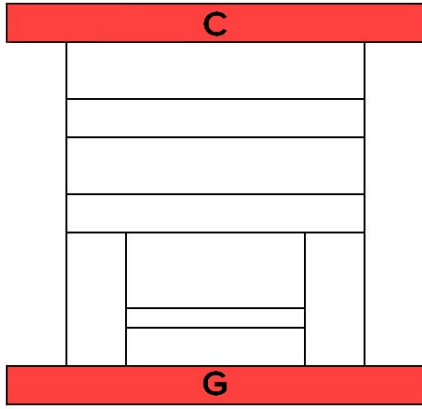

| |
|--------------|
| C - G |
| 36 or 46 |

Material - Mild Steel

DIE PLATE

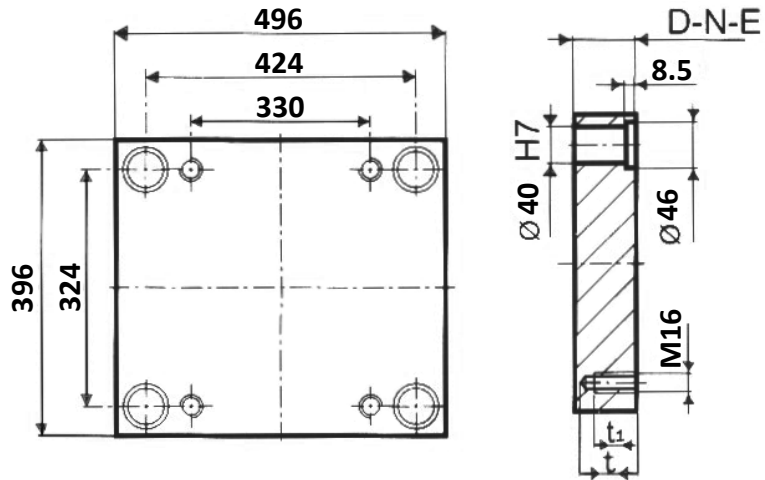
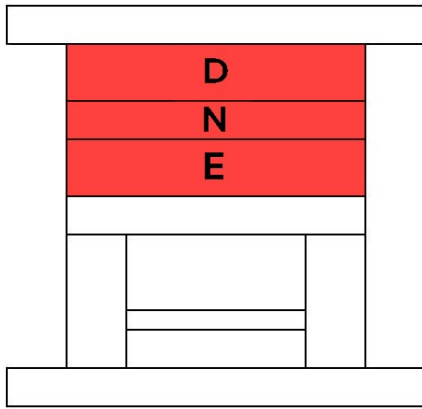

| | | |
|--------------|----|----|
| D-N-E | | |
| 22 | 27 | 36 |
| 46 | 56 | 76 |

Material - 2312

| | |
|----------------|----|
| t ₁ | 24 |
| t | 30 |

SUPPORT

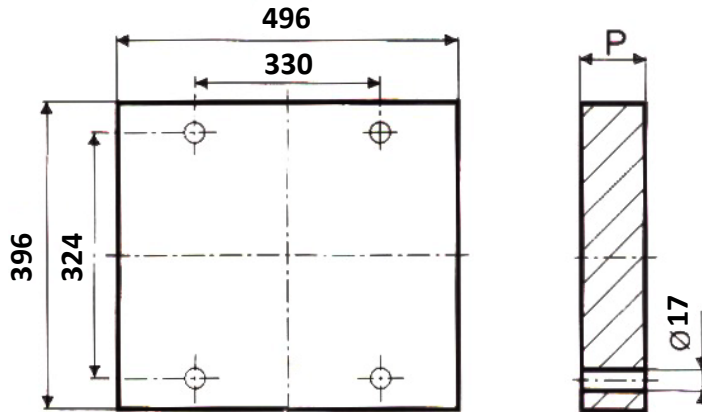
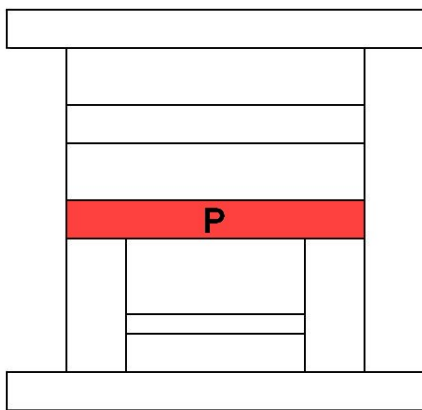

| |
|----------|
| P |
| 36 or 46 |

Material - Mild Steel

RISERS

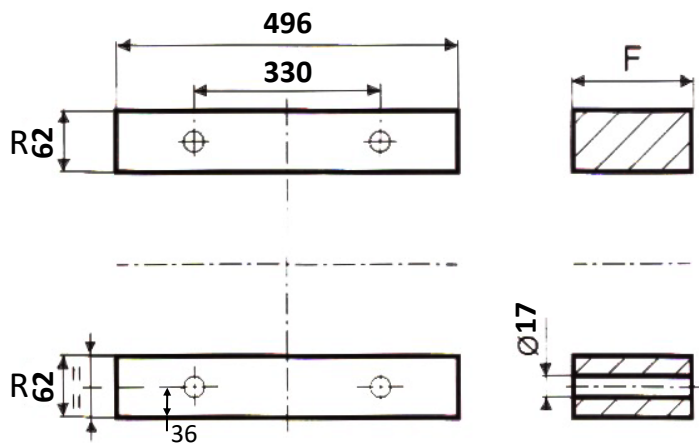
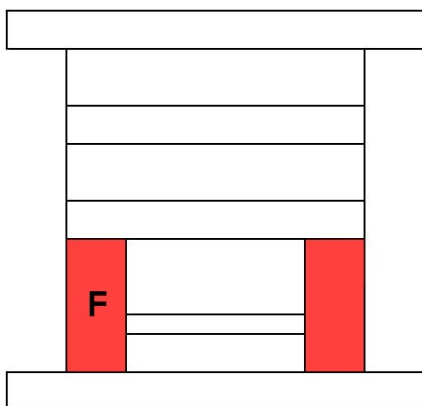

| | | |
|----------|----|----|
| F | | |
| 50 | 60 | 70 |

Material - Mild Steel

| |
|----------|
| R |
| 62 |



396 x 696

DIE

CLAMP PLATE

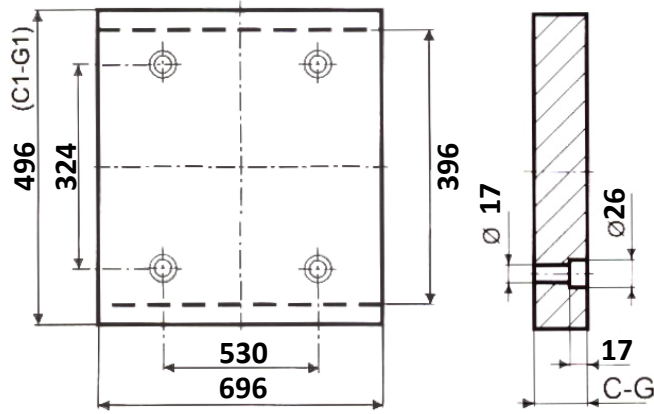
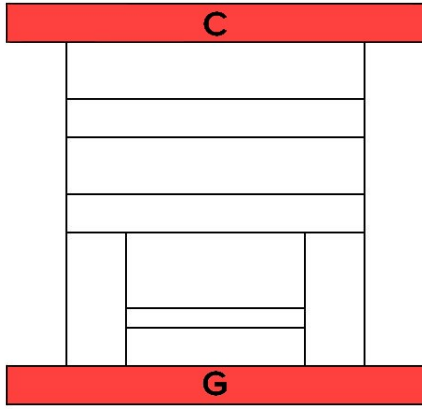

| |
|--------------|
| C - G |
| 36 or 46 |

Material - Mild Steel

DIE PLATE

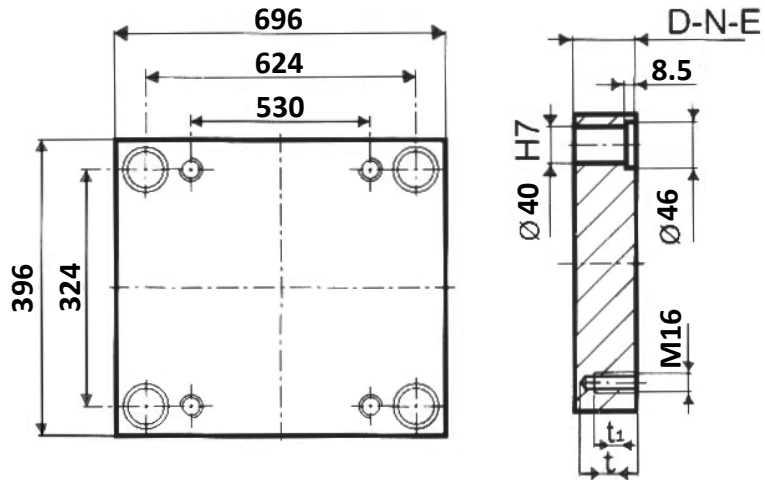
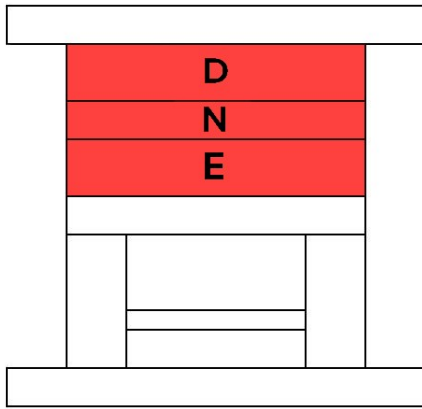

| | | |
|--------------|----|----|
| D-N-E | | |
| 22 | 27 | 36 |
| 46 | 56 | 76 |

Material - 2312

| | |
|----------------|----|
| t ₁ | 24 |
| t | 30 |

SUPPORT

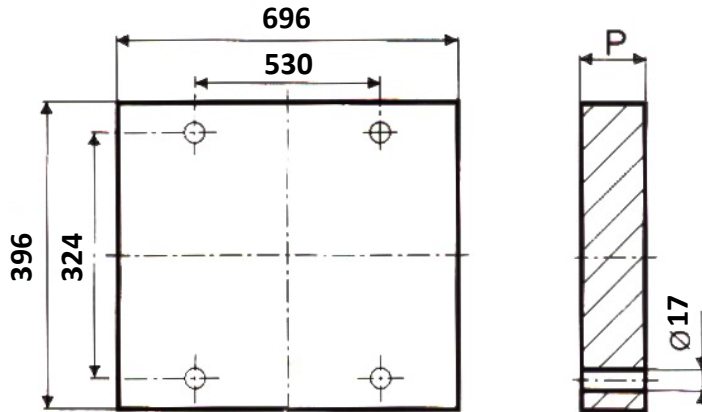
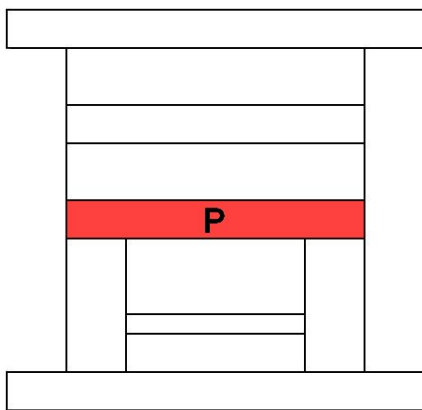

| |
|----------|
| P |
| 36 or 46 |

Material - Mild Steel

RISERS

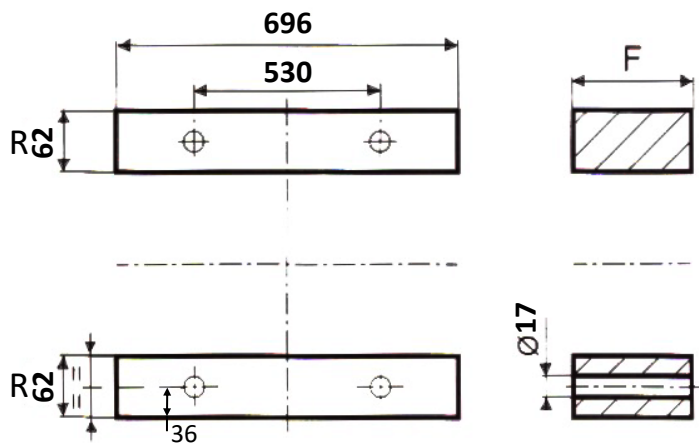
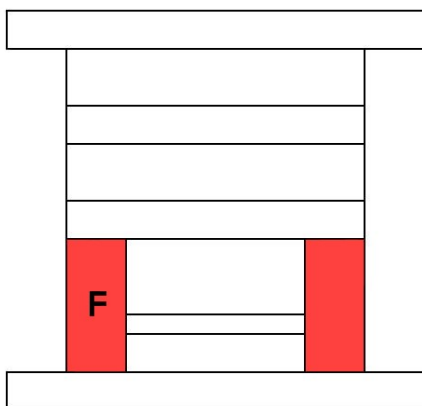

| | | |
|----------|----|----|
| F | | |
| 50 | 60 | 70 |

Material - Mild Steel

| |
|----------|
| R |
| 62 |



396 x 696

DIE

EJECTOR PLATES

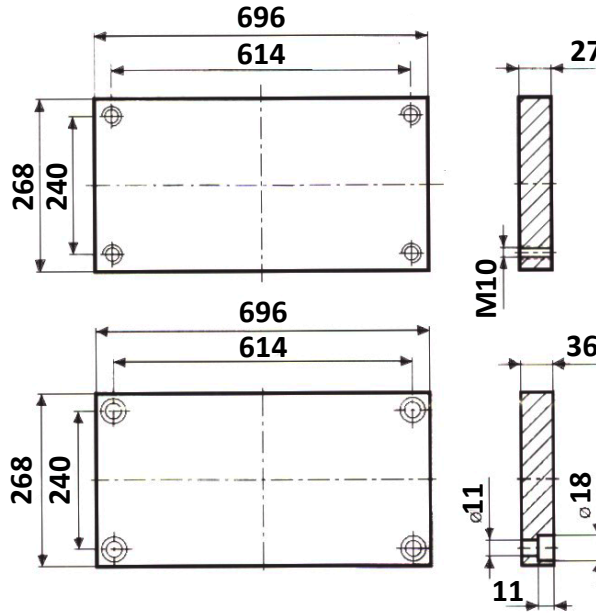
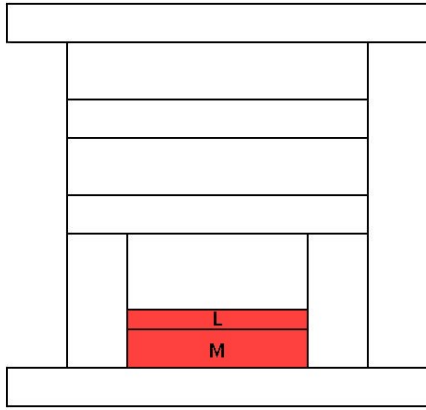

GUIDE PIN - GC

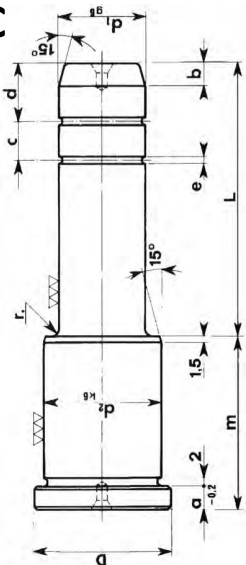

| | | D1 = 30 | | D2 = 40 | | D = 46 | | a = 8 | | |
|----|----|---------|----|---------|----|--------|-----|-------|-----|-----|
| m | L | | | | | | | | | |
| | 36 | 45 | 50 | 70 | 90 | 100 | 125 | 150 | 175 | 200 |
| 26 | ● | ● | | ● | | ● | ● | ● | | |
| 34 | ● | ● | | ● | | ● | ● | ● | ● | ● |
| 44 | | ● | | ● | ● | | ● | ● | ● | ● |
| 54 | ● | | ● | ● | | ● | ● | ● | ● | ● |
| 74 | ● | | ● | ● | | ● | ● | ● | ● | ● |

GUIDE BUSH - CV

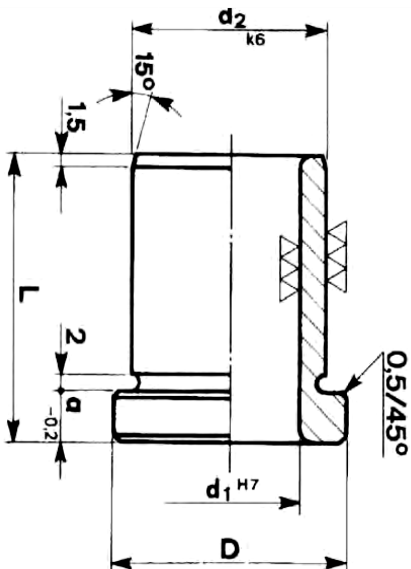

| | | D1 = 30 | | D2 = 40 | | D = 46 | | a = 8 | |
|----|----|---------|----|---------|----|--------|--|-------|--|
| | | L | | | | | | | |
| 26 | 35 | 45 | 55 | 65 | 75 | 95 | | | |
| ● | ● | ● | ● | ● | ● | ● | | | |



446 x 446

DIE

CLAMP PLATE

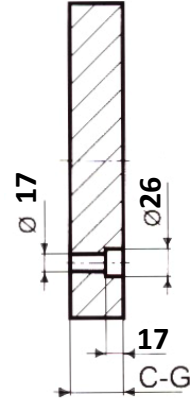
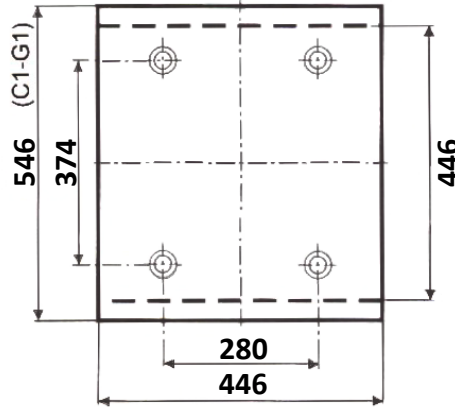
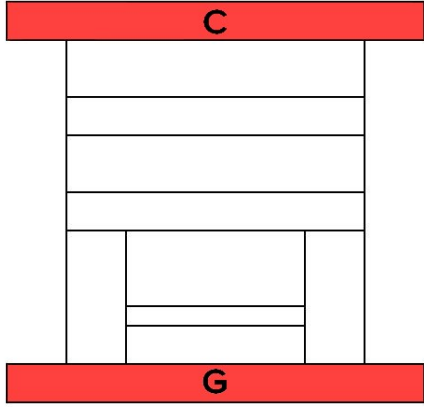

| |
|--------------|
| C - G |
| 36 or 46 |

Material - Mild Steel

DIE PLATE

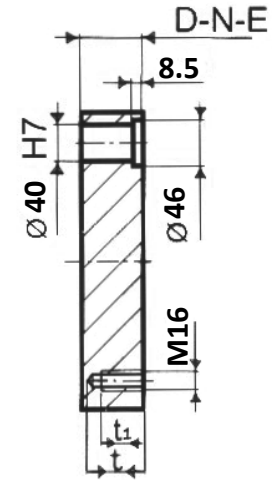
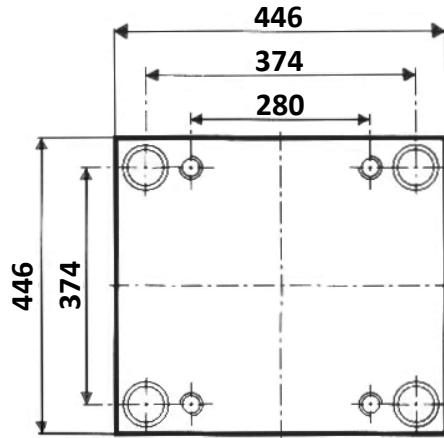
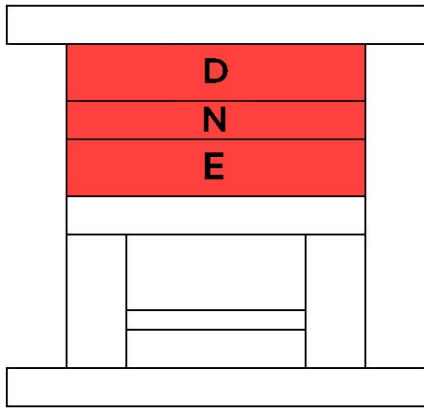

| | | |
|--------------|----|----|
| D-N-E | | |
| 22 | 27 | 36 |
| 46 | 56 | 76 |

Material - 2312

| | |
|----------------|----|
| t ₁ | 24 |
| t | 30 |

SUPPORT

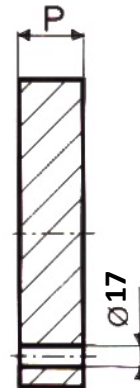
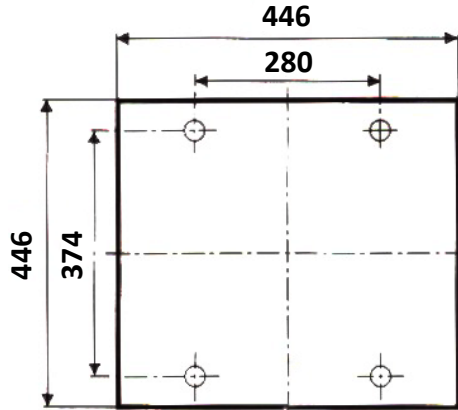
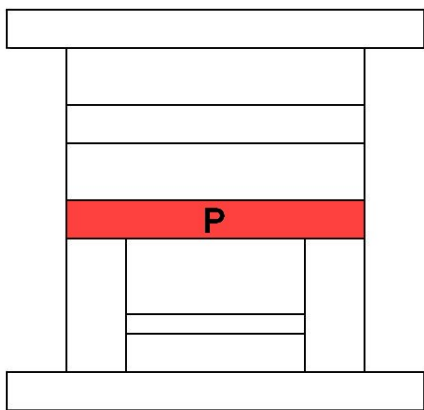

| |
|----------|
| P |
| 36 or 46 |

Material - Mild Steel

RISERS

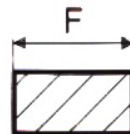
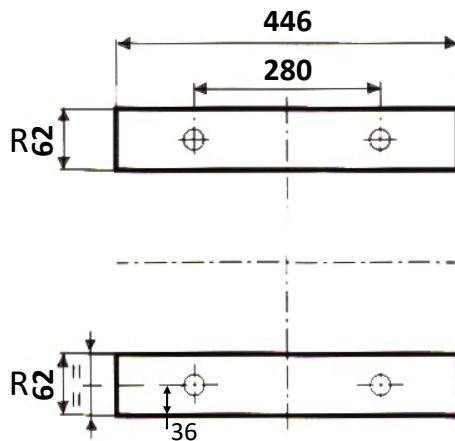
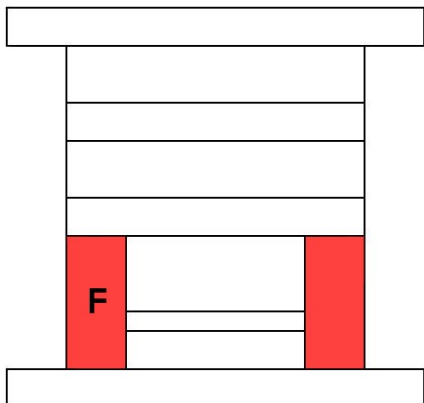

| | | |
|----------|----|----|
| F | | |
| 50 | 60 | 70 |

Material - Mild Steel

| |
|----------|
| R |
| 62 |



446 x 596

DIE

CLAMP PLATE

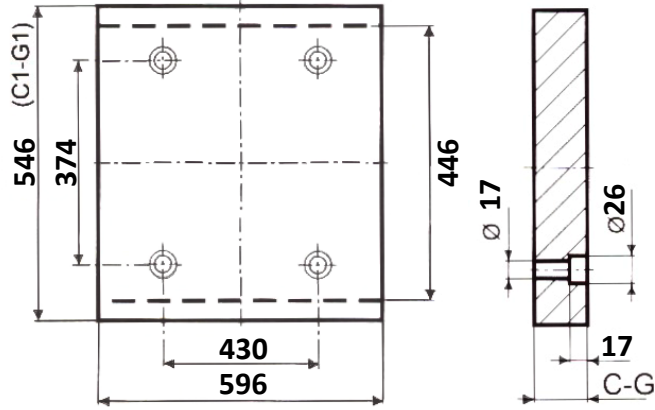
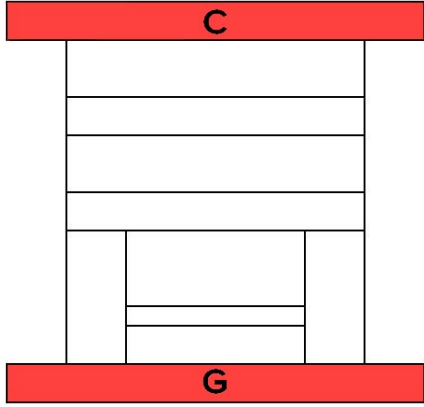

| |
|--------------|
| C - G |
| 36 or 46 |

Material - Mild Steel

DIE PLATE

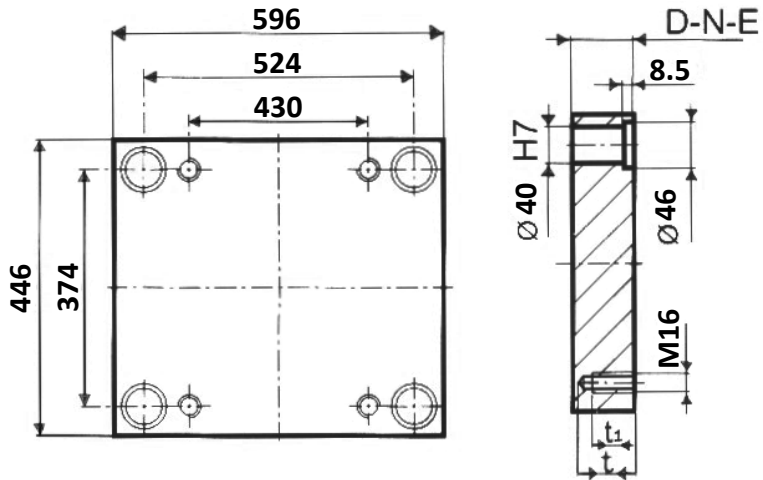
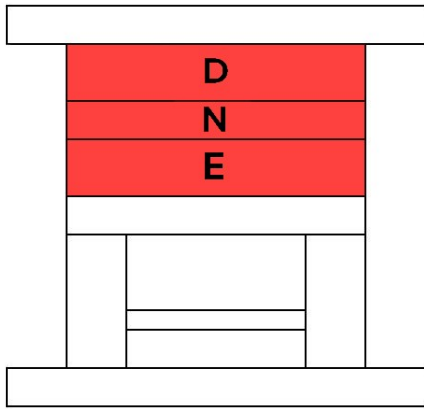

| | | |
|--------------|----|----|
| D-N-E | | |
| 22 | 27 | 36 |
| 46 | 56 | 76 |

Material - 2312

| | |
|----------------|----|
| t ₁ | 24 |
| t | 30 |

SUPPORT

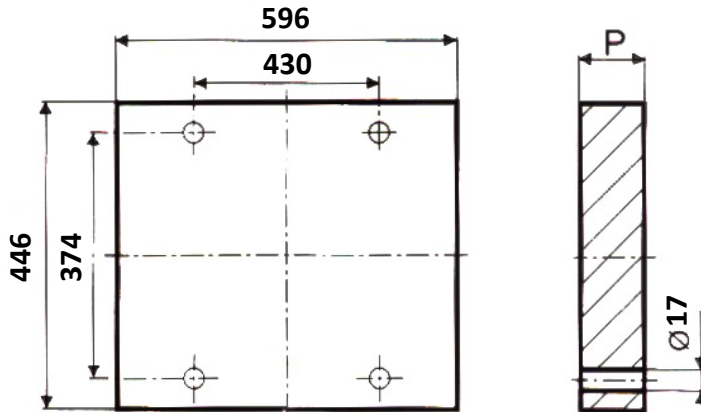
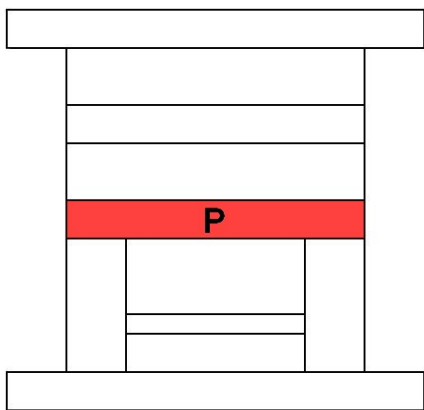

| |
|----------|
| P |
| 36 or 46 |

Material - Mild Steel

RISERS

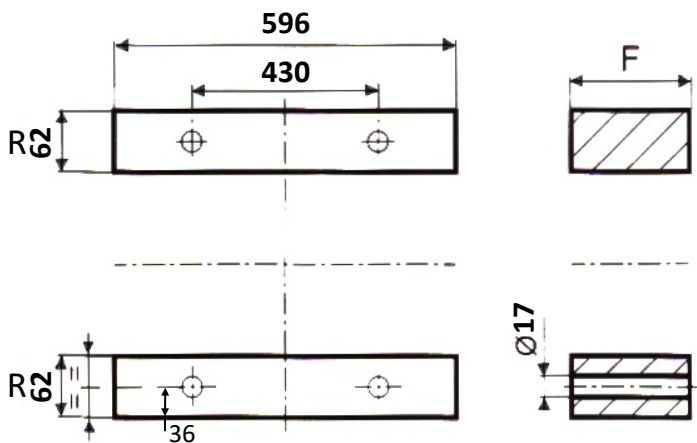
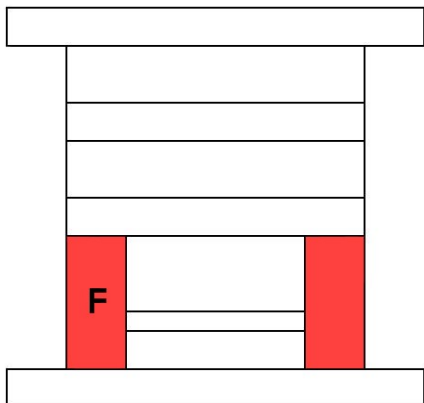

| | | |
|----------|----|----|
| F | | |
| 50 | 60 | 70 |

Material - Mild Steel

| |
|----------|
| R |
| 62 |



446 x 696

DIE

CLAMP PLATE

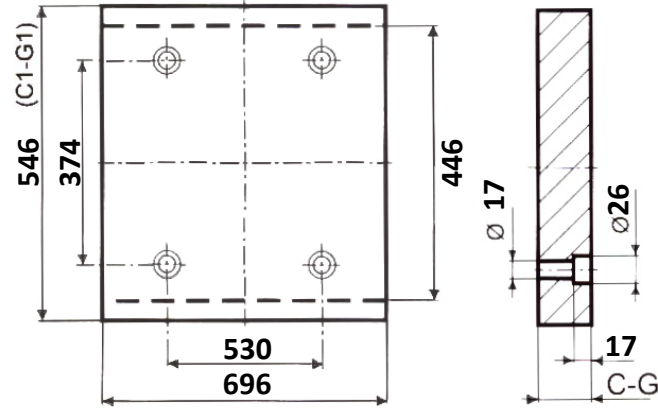
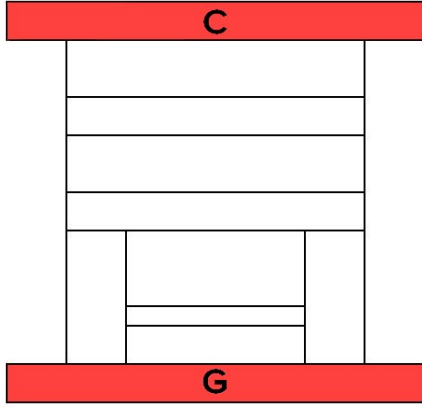

| |
|-------|
| C - G |
| 56 |

Material - Mild Steel

DIE PLATE

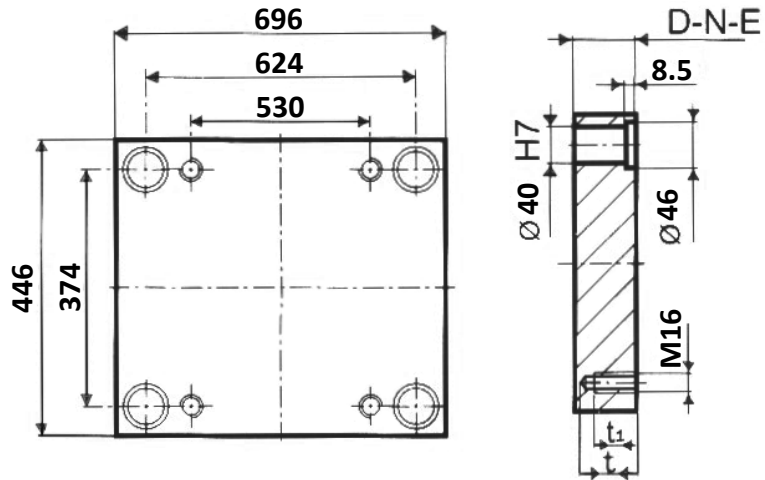
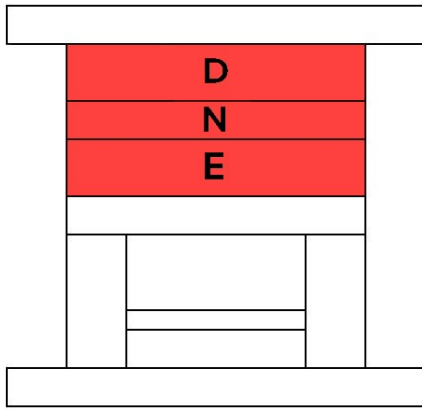

| | | |
|-------|--|--|
| D-N-E | | |
| 22 | | |
| 27 | | |
| 36 | | |
| 46 | | |
| 56 | | |
| 76 | | |

Material - 2312

| | |
|----------------|----|
| t ₁ | 24 |
| t | 30 |

SUPPORT

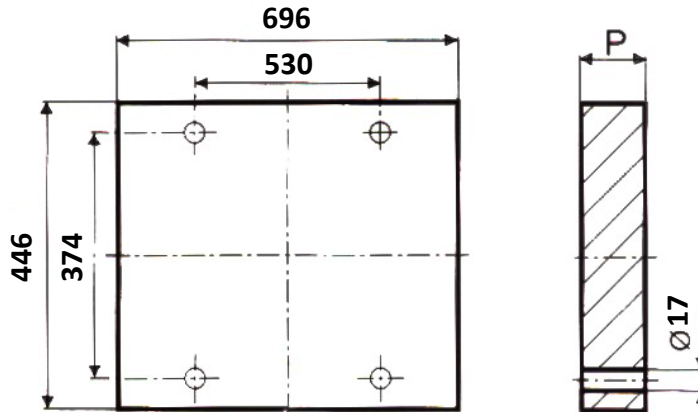
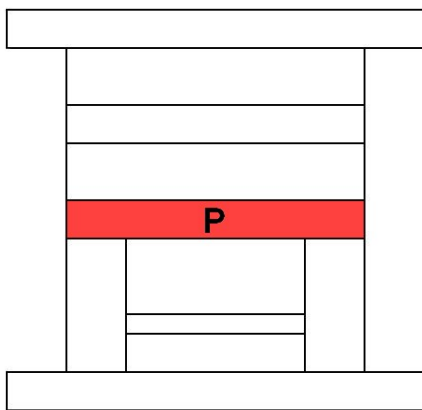

| |
|----------|
| P |
| 36 or 46 |

Material - Mild Steel

RISERS

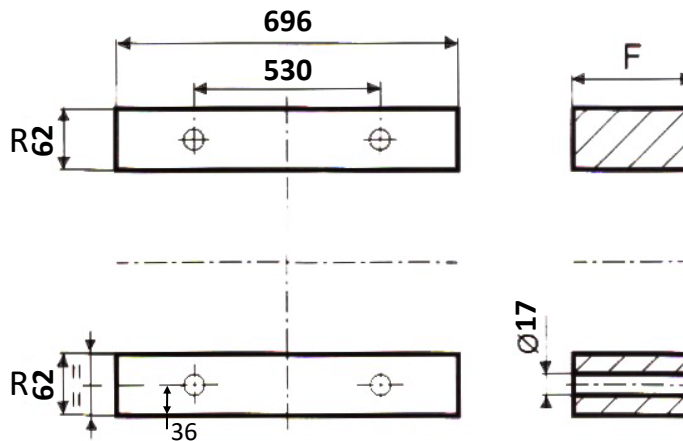
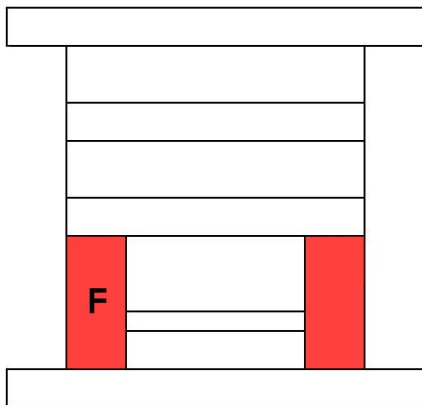

| | | |
|----|----|----|
| F | | |
| 50 | 60 | 70 |

Material - Mild Steel

| |
|----|
| R |
| 62 |



496 x 496

DIE

CLAMP PLATE

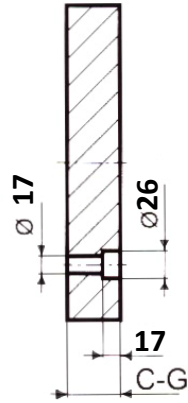
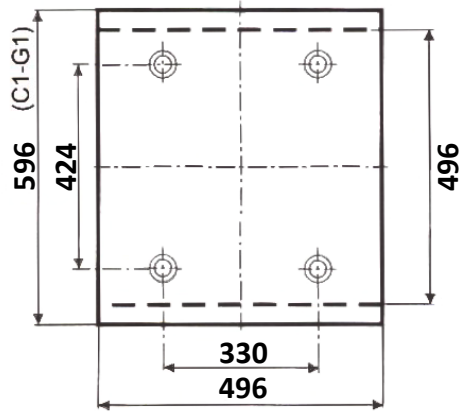
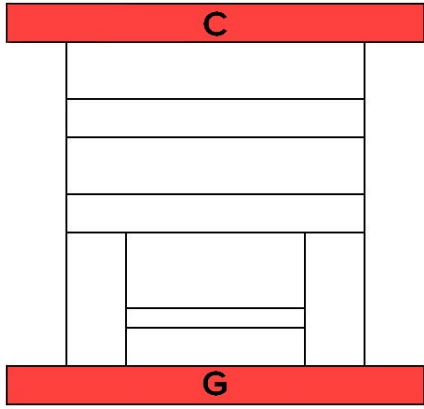

C - G

36, 46 or 56

Material - Mild Steel

DIE PLATE

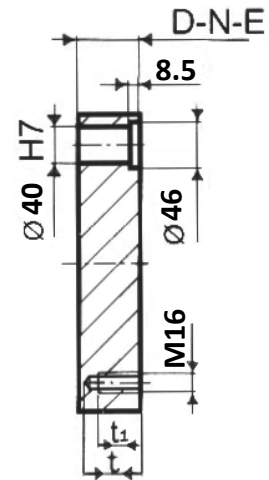
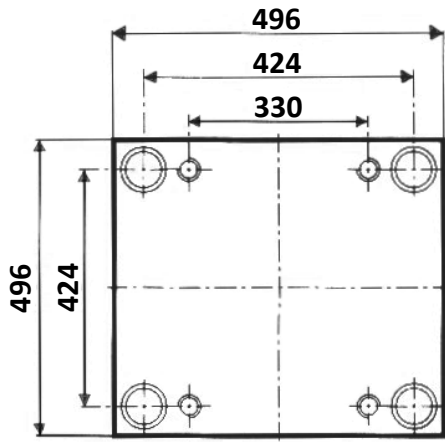
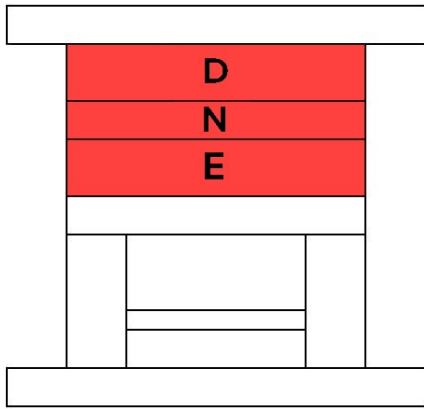

D-N-E

| | | |
|----|----|----|
| 22 | 27 | 36 |
| 46 | 56 | 76 |

| | | |
|----|----|----|
| 22 | 27 | 36 |
| 46 | 56 | 76 |

Material - 2312

| | |
|----------------|----|
| t ₁ | 24 |
| t | 30 |

| | |
|----------------|----|
| t ₁ | 24 |
| t | 30 |

SUPPORT

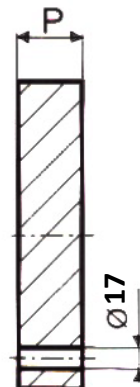
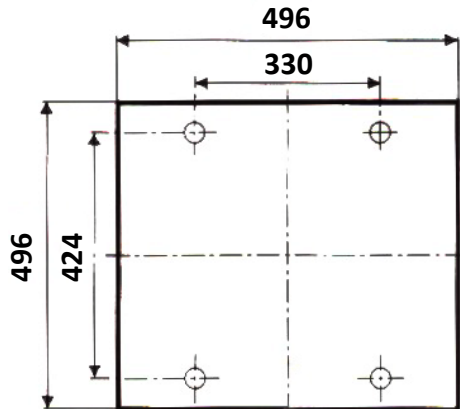
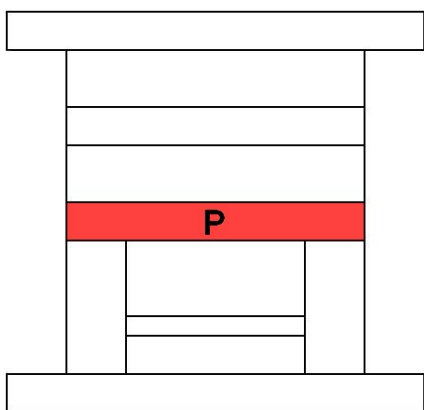

P

36, 46 or 56

Material - Mild Steel

RISERS

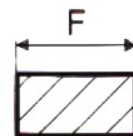
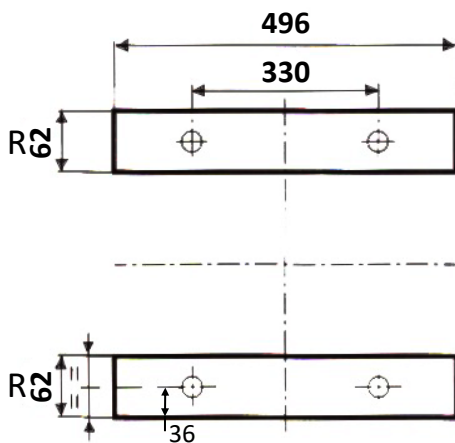
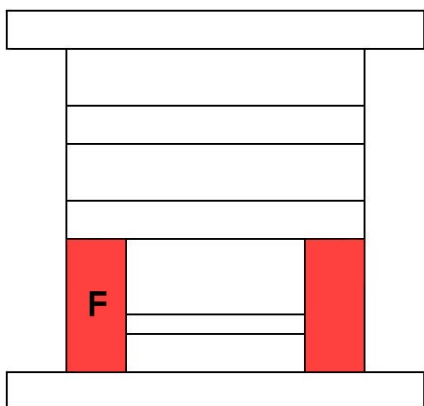

F

| | | |
|----|-----|-----|
| 50 | 60 | 70 |
| 90 | 100 | 150 |

| | | |
|----|-----|-----|
| 50 | 60 | 70 |
| 90 | 100 | 150 |

Material - Mild Steel

R

62



496 x 596

DIE

CLAMP PLATE

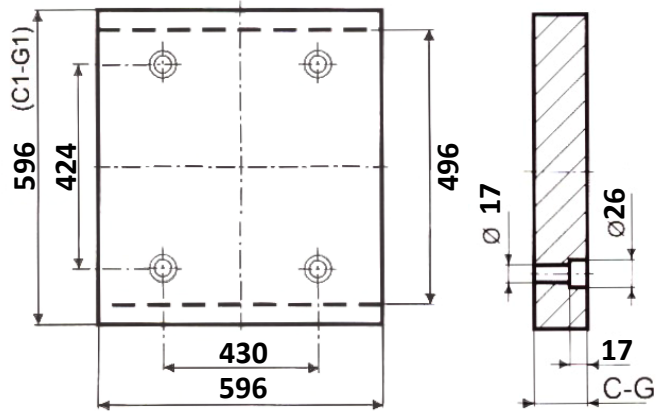
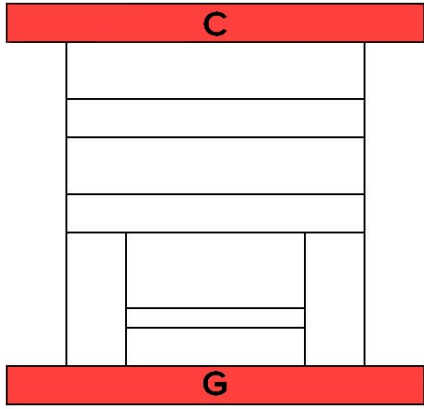

| |
|--------------|
| C - G |
| 36, 46 or 56 |

Material - Mild Steel

DIE PLATE

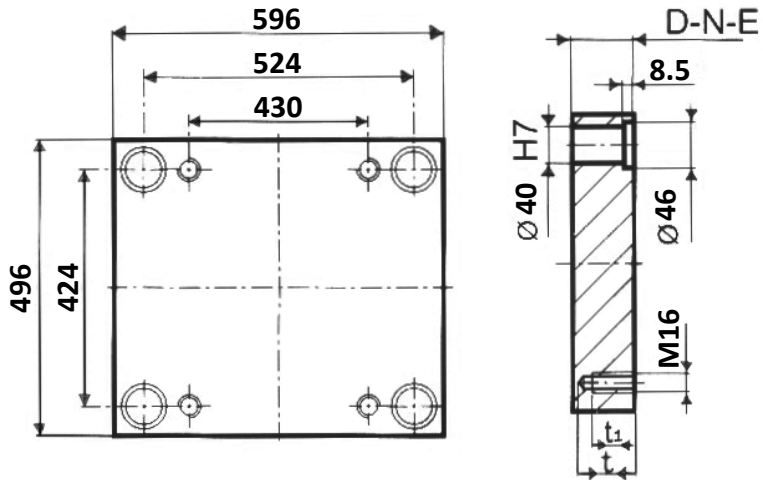
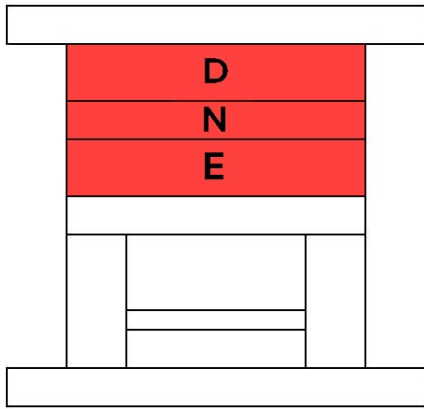

| | | |
|--------------|----|----|
| D-N-E | | |
| 22 | 27 | 36 |
| 46 | 56 | 76 |

Material - 2312

| | |
|----------------|----|
| t ₁ | 24 |
| t | 30 |

SUPPORT

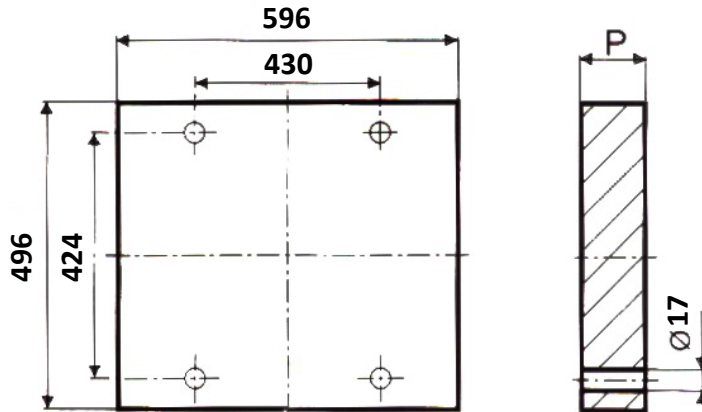
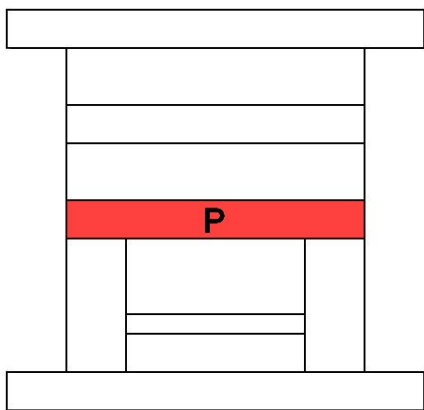

| |
|--------------|
| P |
| 36, 46 or 56 |

Material - Mild Steel

RISERS

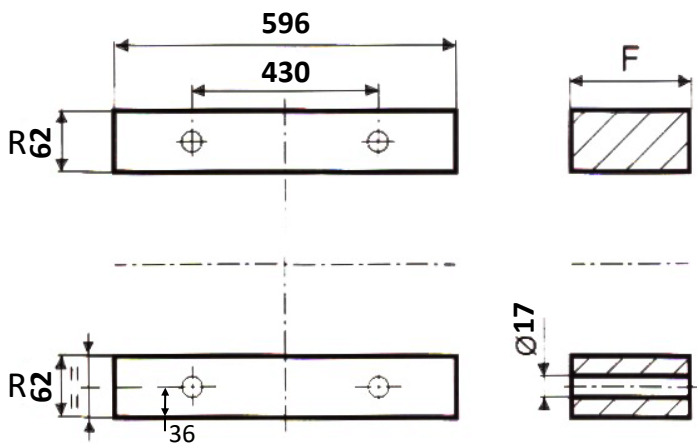
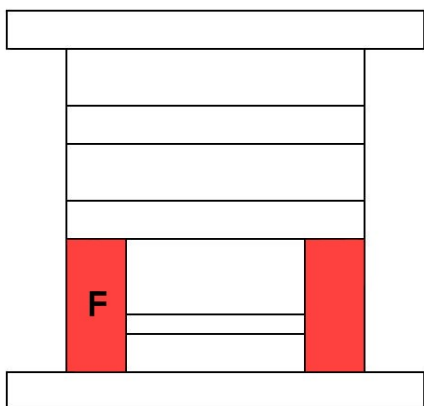

| | | |
|----------|-----|-----|
| F | | |
| 50 | 60 | 70 |
| 90 | 100 | 150 |

Material - Mild Steel

| |
|----------|
| R |
| 62 |



496 x 696

DIE

CLAMP PLATE

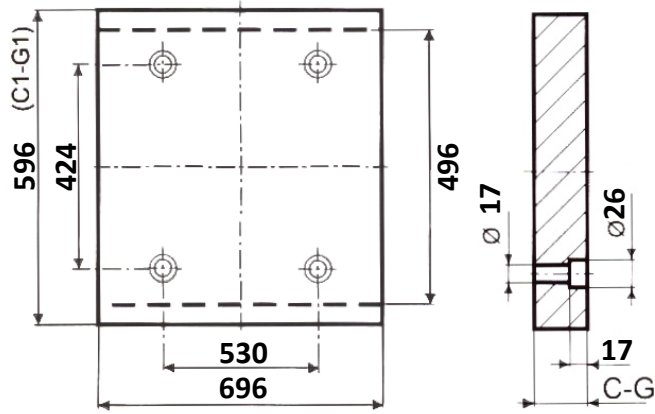
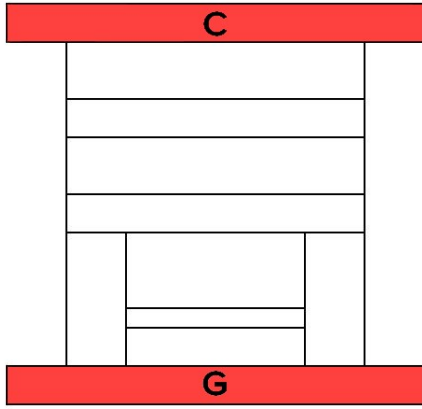

| |
|--------------|
| C - G |
| 36, 46 or 56 |

Material - Mild Steel

DIE PLATE

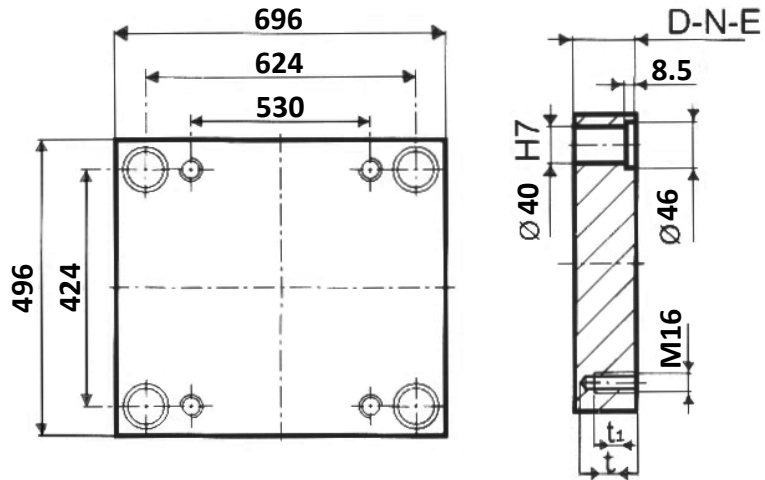
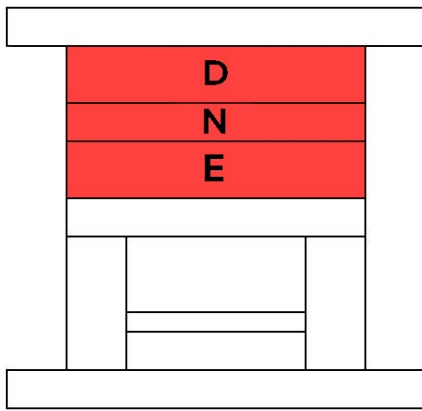

| | | |
|--------------|----|----|
| D-N-E | | |
| 22 | 27 | 36 |
| 46 | 56 | 76 |

Material - 2312

| | |
|----------------|----|
| t ₁ | 24 |
| t | 30 |

SUPPORT

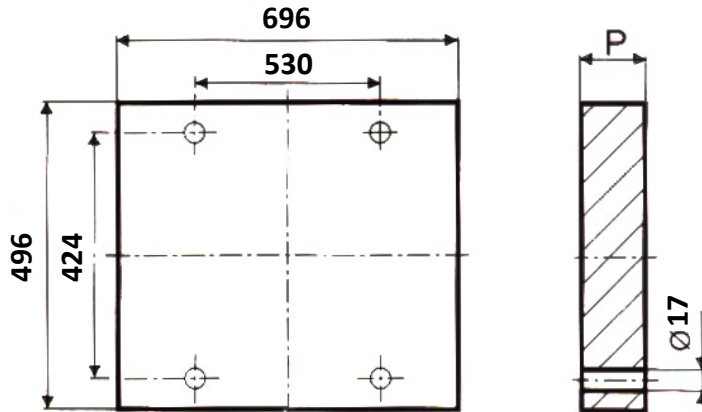
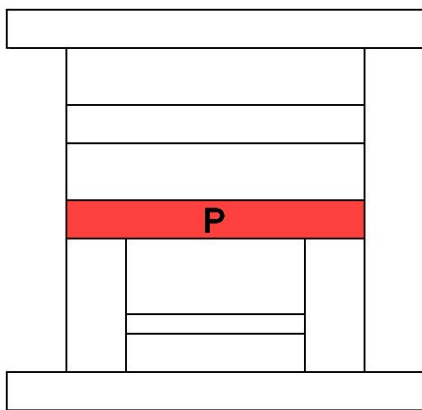

| |
|--------------|
| P |
| 36, 46 or 56 |

Material - Mild Steel

RISERS

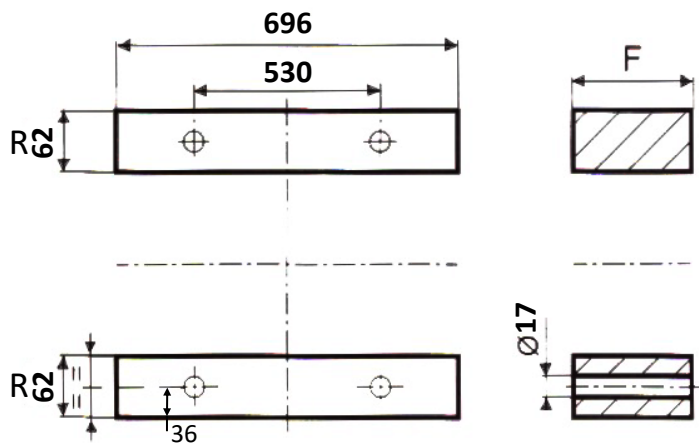
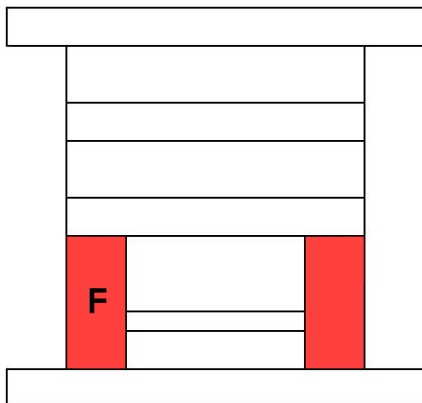

| | | |
|----------|-----|-----|
| F | | |
| 50 | 60 | 70 |
| 90 | 100 | 150 |

Material - Mild Steel

| |
|----------|
| R |
| 62 |

